

DUAL DUCT

TERMINAL UNITS

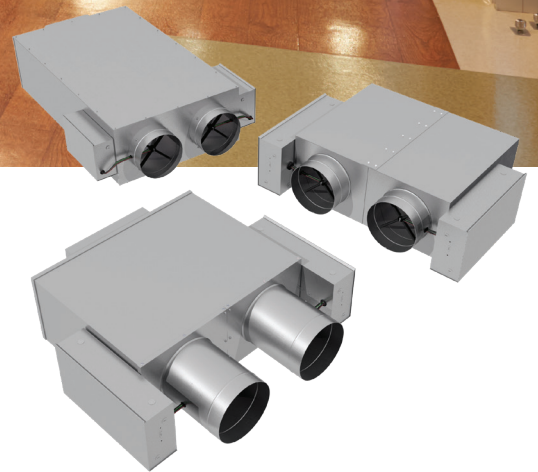

DUAL DUCT Terminal Units

Price Dual Duct terminal units precisely regulate the flow of conditioned air to a room or zone in response to thermostat demand for cooling or heating. Different levels of mixing performance are available, plus a range of design options to suit a wide variety of specification requirements.

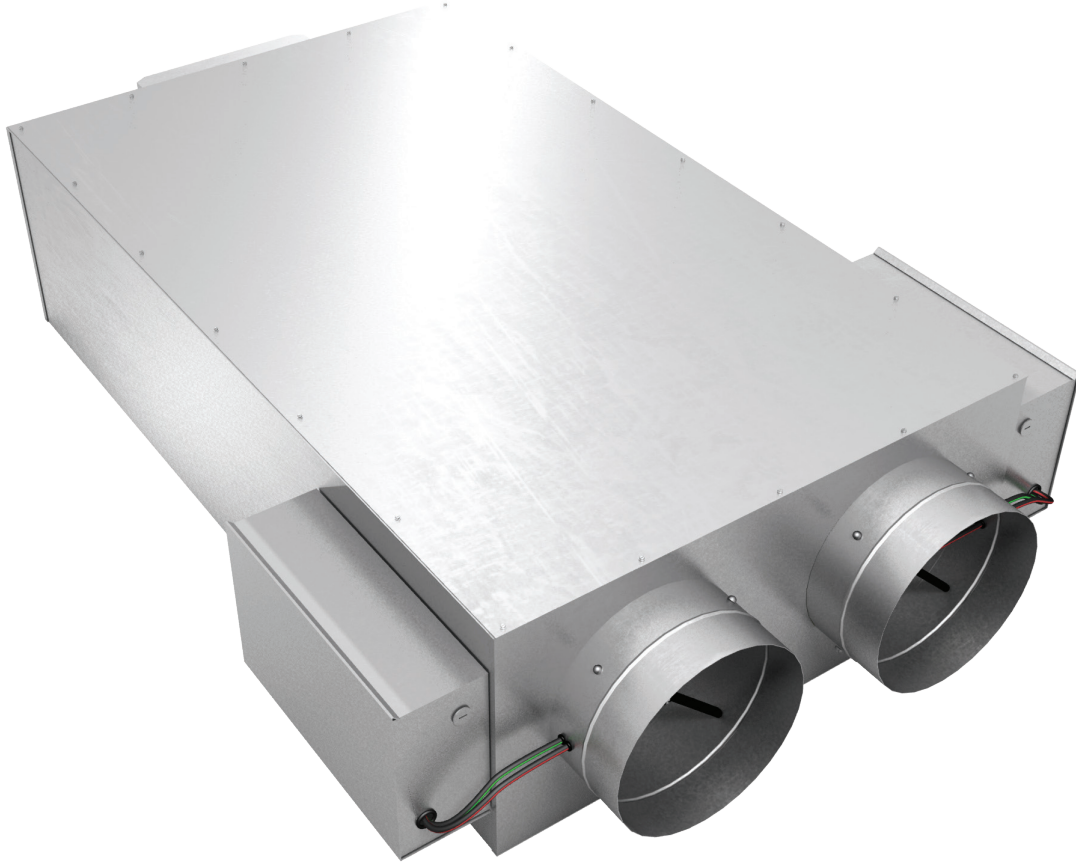

High Mixing Dual Duct Terminal Unit

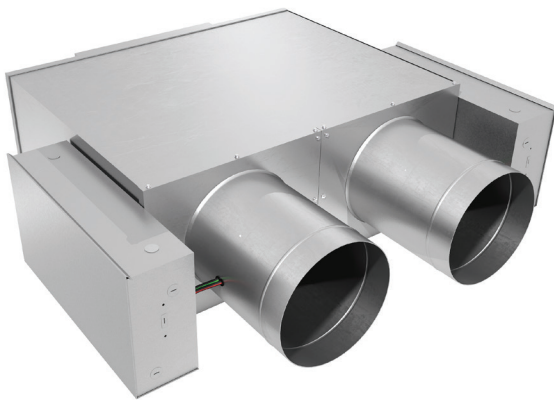

Standard Mixing Dual Duct Terminal Unit



Non Mixing Dual Duct Terminal Unit

CONTROLS

Price offers a complete line of controls to best suit any application. For exceptional user comfort, the Price Intelligent Controller (PIC) universal DDC control package is available factory installed and configured on all dual duct units. The PIC can be used in conjunction with any Price thermostat, designed with an intuitive and clean user interface for easy adjustment of setpoints and parameters.

OPTIONS AND ACCESSORIES

A complete line of accessories are offered to meet specific job requirements. For additional options and accessories please refer to the Terminal Units Accessories catalog.

MIXING PERFORMANCE

Non-mixing units are an economical, manufacturer's solution to bring two airstreams together in preparation to be mixed further downstream.

Dual ducts with standard mixing performance circumvent the potential for thermal stratification by providing a uniform discharge air temperature profile of +/- 1°F for every 10°F temperature differential between the hot and cold decks at a downstream distance of three equivalent duct diameters.

For the best mixing performance, high mixing dual ducts deliver a mixing ratio as high as 20:1. At only six inches from the unit discharge, high mixing dual ducts provide a uniform discharge air temperature profile of +/- 1°F for every 20°F temperature differential between the hot and cold decks.

TYPICAL APPLICATIONS

Dual duct terminal units provide an excellent alternative to traditional single duct ventilation, particularly in systems requiring isolated hot and cold conditioned airstreams. Dual duct terminals offer pressure independent control of separate hot and cold air flow, discharging a blended single airstream.

STANDARD DESIGN

- + Gasketed damper and mechanically sealed, 22 GA. casing for minimal leakage
- + Integral mixing baffles
- + Separate hot/cold inlet airflow sensors, and downstream total flow sensor
- + Labelled hot and cold deck location for ease of installation
- + Models
 - Mixing (DDS)
 - High Mixing (DDM)
 - Non-Mixing (DDV)

OPTIONAL FEATURES

- + Mismatched hot/cold inlet sizes for design flexibility
- + Multiple liner options
- + Separate discharge attenuator section (DDQ)
- + Tuned discharge silencer (DDUQ)

DUAL DUCT Terminal Units

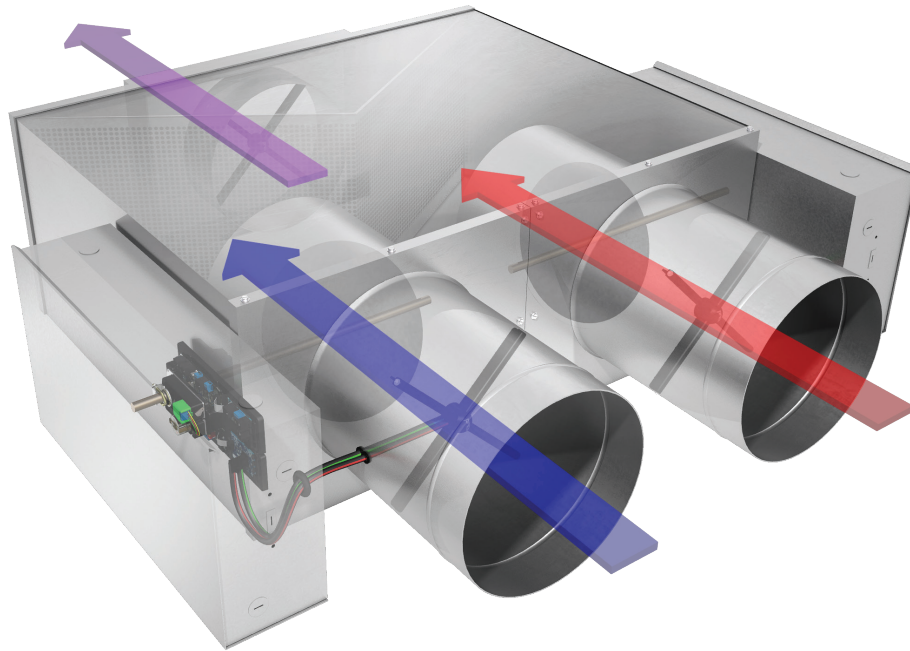

DDS – STANDARD MIXING

The DDS is a compact, standard mixing dual duct terminal unit, ideal for projects with space limitations and normal sound and mixing requirements. The terminal unit precisely regulates the flow of conditioned air to a room or zone in response to thermostat demand for cooling or heating. With three individual airflow sensors, located in both inlets and the outlet, the DDS offers flexibility to the controls contractor to install their controls using whichever combination of valves they require.

Sound sensitive applications that require further discharge attenuation can make use of a discharge attenuator (DDQ) or a silencer (DDUQ). These close-coupled integral assemblies are tested in Price's own NVLAP-accredited laboratory (NVLAP Lab Code 200874-0) to ensure the highest quality of manufacturing and performance.

Discharge Attenuator

Attenuators provide additional discharge sound attenuation to meet the requirements of noise-sensitive applications. The attenuator reduces discharge sound power levels and improves mixing efficiency.

Quiet Construction

For ultra-sound sensitive applications, Price eliminates the guess work of untested solutions, by providing an optimized and fully tested assembly.

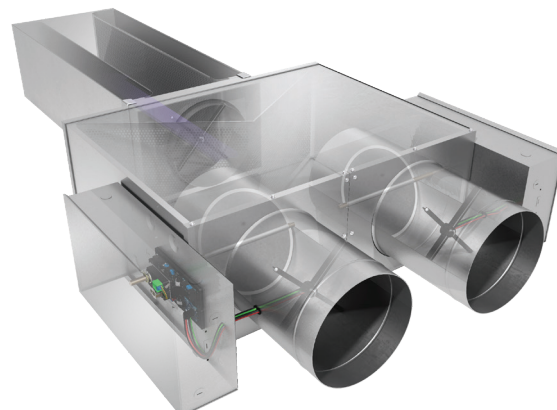
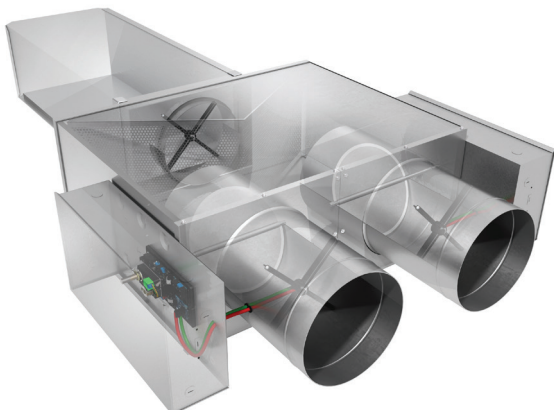

DUAL DUCT Terminal Units

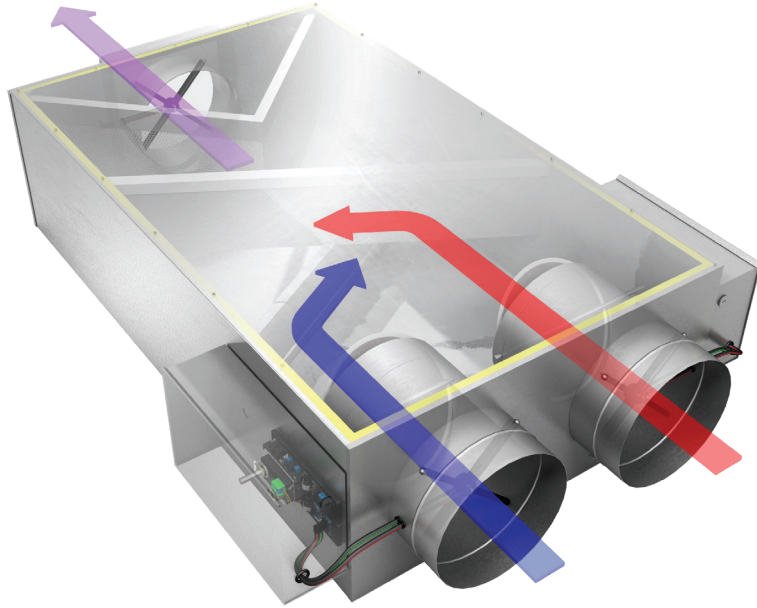

DDM – HIGH-MIXING

The DDM is a high mixing dual duct terminal unit, ideal for projects with critical discharge air temperature requirements. The terminal unit precisely regulates the flow of conditioned air while providing an average discharge temperature with variations within 1°F for every 20°F temperature difference between the hot and cold decks.

The DDM includes three individual airflow sensors, located in both inlets and the outlet. This allows for greater flexibility selecting a control sequence to maximize efficiency.

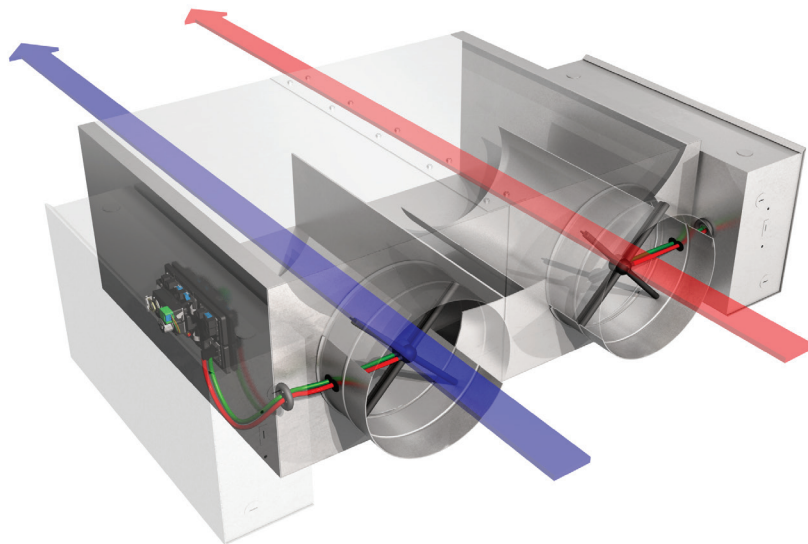

DDV – NON-MIXING

The DDV is an economical, non-mixing dual duct terminal unit that precisely regulates the flow of conditioned air to a room or zone in response to thermostat demand for cooling or heating. The DDV is essentially two single duct terminal units fastened together.

The inlets are typically connected to two of the following: cold air supply, warm air supply, or fresh air supply. Separate airflow sensors are supplied in each inlet.

DIMENSIONAL DATA

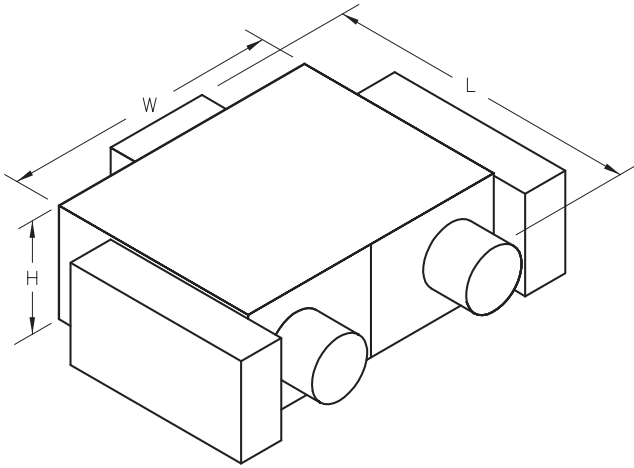

DDS Basic Box

Size	Length (L)	Width (W)	Height (H)
4	32 in.	21 in.	10 in.
5			
6	30 in.		
7			
8	32 in.	25 in.	12 1/2 in.
9			
10	40 in.	29 in.	15 in.
12	47 1/4 in.	40 1/8 in.	17 1/2 in.
14	54 in.	48 1/8 in.	18 in.

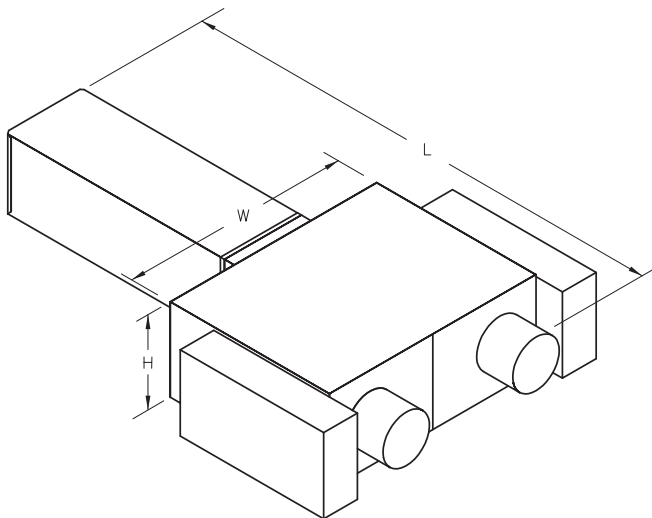

DDS with Attenuator (DDQ)

Size	Length (L)	Width (W)	Height (H)
4	68 in.	21 in.	10 in.
5			
6	66 in.		
7			
8	68 in.	25 in.	12 1/2 in.
9			
10	76 in.	29 in.	15 in.
12	83 1/4 in.	40 in.	17 1/2 in.
14	90 in.	48 in.	18 in.

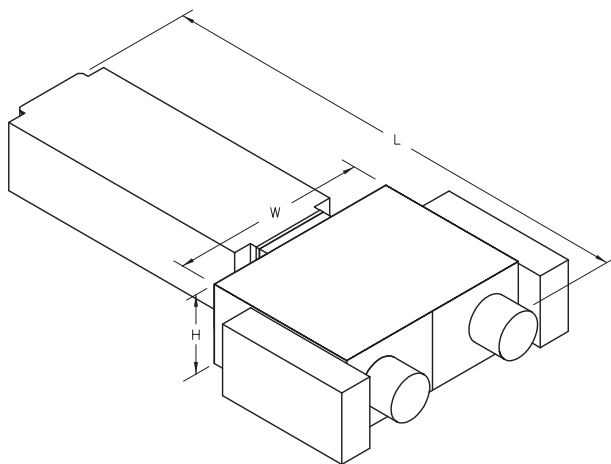

DDS with Silencer (DDUQ)

Size	Length (L)		Width (W)	Height (H)
	With FG Liner	With FC/PL Liner		
4	68 in.		21 in.	10 in.
5				
6	66 in.			
7				
8	68 in.		25 in.	12 1/2 in.
9				
10	76 in.	100 in.	29 in.	15 in.
12	83 1/4 in.	107 1/4 in.	40 in.	17 1/2 in.
14	90 in.	114 in.	48 in.	18 in.

DUAL DUCT Terminal Units

DIMENSIONAL DATA

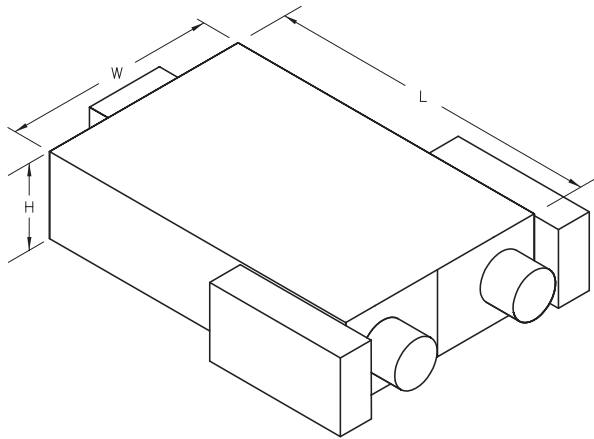

DDM Basic Box

Size	Length (L)	Width (W)	Height (H)
4	47 in.	24 in.	12 1/2 in.
5			
6			
7			
8			
9	55 in.	32 in.	15 in.
10			
12	60 in.	40 in.	17 1/2 in.
14			
16	72 in.	48 in.	18 in.

Inlet Lengths

- Size 4-6 – 6 3/8 in.
- Size 7-16 – 4 3/8 in.

Discharge Collar

- 4 in.
- Size 7-10: 6 1/2 in.

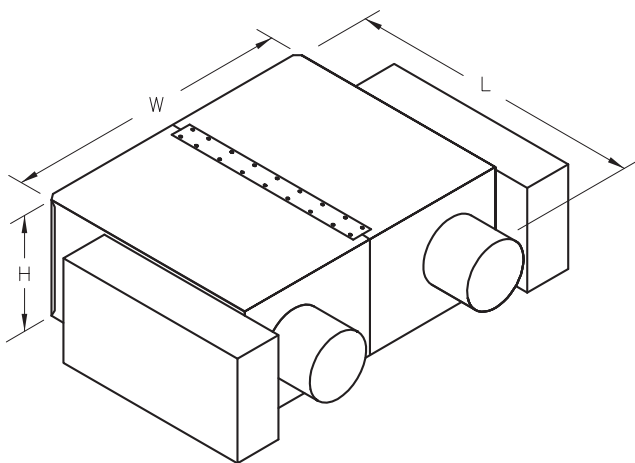

DDV Basic Box

Size	Length (L)	Width (W)	Height (H)
4	22 1/8 in.	24 1/8 in.	8 in.
5			
6	20 1/8 in.		10 in.
7			
8			
9		28 1/8 in.	12 1/2 in.
10			
12	32 1/8 in.	15 in.	
14			
16	23 5/8 in.	40 1/8 in.	17 1/2 in.
16			

PERFORMANCE DATA



Dual Duct AHRI Certification Rating Points

DPS, DDS – Standard Model

Unit Size	Rated Airflow cfm	Minimum Operating Pressure Required in. Water	Radiated Sound Power Level, dB at 1.5 in.w.g. Octave Band							Discharge Sound Power Level, dB at 1.5 in.w.g. Octave Band						
			2	3	4	5	6	7	2	3	4	5	6	7		
4	150	0.27	50	44	43	37	34	30	65	56	49	39	41	37		
5	250	0.32	55	47	45	37	34	30	69	60	53	45	46	43		
6	400	0.71	59	50	47	38	34	30	76	65	60	50	51	51		
7	550	0.58	64	53	48	41	38	34	78	69	63	54	55	52		
8	700	0.57	65	55	50	42	38	37	78	69	63	56	56	54		
9	900	0.52	65	55	50	42	39	37	78	68	63	56	56	55		
10	1100	0.54	65	56	52	43	39	37	79	68	64	57	57	56		
12	1600	0.48	65	57	52	45	39	38	78	68	66	57	58	58		
14	2100	0.41	66	58	53	45	41	39	77	69	66	57	59	61		
16	2800	0.60	66	58	55	46	43	43	76	69	66	58	59	61		

DPM, DDM – High-Mixing Model

Unit Size	Rated Airflow cfm	Minimum Operating Pressure Required in. Water	Radiated Sound Power Level, dB at 1.5 in.w.g. Octave Band							Discharge Sound Power Level, dB at 1.5 in.w.g. Octave Band						
			2	3	4	5	6	7	2	3	4	5	6	7		
4	150	0.21	56	51	41	34	31	31	61	45	37	37	32	28		
5	250	0.19	56	50	42	35	31	26	66	49	39	39	35	29		
6	400	0.41	59	55	46	39	34	29	70	57	46	46	43	40		
7	550	0.44	63	52	44	37	35	31	73	60	52	51	48	45		
8	700	0.49	64	52	45	37	33	33	76	63	54	53	51	46		
9	900	0.4	62	54	47	39	34	31	75	60	55	51	51	46		
10	1100	0.55	62	55	47	38	31	27	76	61	56	51	50	49		
12	1600	0.37	64	56	47	39	35	37	77	62	53	51	49	42		
14	2100	0.52	70	55	51	41	36	30	78	64	60	55	53	49		
16	2800	0.44	70	59	53	45	39	34	76	64	60	54	52	48		

Performance Notes:

1. cfm, cubic feet per minute.
2. Sound power levels expressed in decibels, (dB) re 10⁻¹² watts.
3. Sound power levels include duct end corrections per AHRI Standard 880-2017.

PERFORMANCE DATA

DPS / DDS – Standard Mixing Model - Typical Selection Guide

Unit Size	Airflow	Min. ΔPs Across Unit	Min. ΔPt.	Discharge NC ΔPs Across Unit				Radiated NC ΔPs Across Unit			
	cfm	in.w.g.	in.w.g.	0.5 in.w.g.	1.0 in.w.g.	1.5 in.w.g.	3.0 in.w.g.	0.5 in.w.g.	1.0 in.w.g.	1.5 in.w.g.	3.0 in.w.g.
4	75	0.07	0.12	--	--	--	--	--	--	--	--
	100	0.12	0.20	--	--	--	--	--	--	--	--
	150	0.26	0.44	--	--	21	23	--	--	--	--
	200	0.47	0.79	--	26	27	29	--	--	21	23
	225	0.59	1.00	*	29	30	31	*	21	22	25
5	150	0.12	0.19	--	--	--	20	--	--	--	--
	200	0.21	0.34	--	--	22	26	--	--	--	21
	250	0.32	0.52	--	24	27	31	--	--	--	23
	300	0.46	0.75	--	24	27	31	--	--	21	25
	350	0.63	1.03	*	27	30	34	*	21	23	27
6	200	0.18	0.24	--	--	20	24	--	--	--	--
	250	0.28	0.37	--	22	25	29	--	--	--	21
	300	0.40	0.53	--	22	25	29	--	--	--	23
	350	0.54	0.72	*	26	28	33	*	--	--	25
	400	0.71	0.95	*	29	31	36	*	--	21	27
7	200	0.08	0.11	--	--	--	22	--	--	--	--
	300	0.17	0.24	--	--	21	27	--	--	--	--
	400	0.31	0.44	--	24	27	33	--	--	20	24
	500	0.48	0.68	--	29	32	38	--	23	25	29
	550	0.58	0.82	*	31	34	40	*	25	27	31
8	350	0.14	0.19	--	--	21	28	--	--	--	23
	450	0.23	0.32	--	22	26	32	--	--	21	25
	550	0.35	0.48	--	26	29	35	--	22	25	29
	700	0.57	0.78	--	30	33	39	22	26	29	33
	750	0.65	0.89	*	28	32	38	*	28	30	34
9	400	0.10	0.14	--	--	--	24	--	--	--	24
	550	0.19	0.27	--	21	24	30	--	--	22	28
	700	0.31	0.45	--	25	29	34	--	22	25	31
	900	0.52	0.74	--	28	31	37	--	25	29	35
	1000	0.64	0.92	*	30	33	39	*	27	30	36
10	500	0.11	0.15	--	--	22	28	--	--	--	26
	700	0.22	0.30	--	24	27	34	--	--	23	29
	900	0.36	0.50	--	25	29	35	--	23	26	33
	1100	0.54	0.74	*	29	32	39	*	25	29	35
	1300	0.75	1.03	*	31	35	41	*	28	31	38
12	700	0.09	0.13	--	--	--	26	--	--	--	25
	1000	0.19	0.27	--	--	23	30	--	--	22	29
	1300	0.31	0.44	--	23	27	34	--	22	26	33
	1600	0.48	0.68	--	27	31	38	--	25	29	35
	1900	0.67	0.95	*	30	34	41	*	27	31	38
14	1000	0.09	0.13	--	--	21	28	--	--	21	28
	1475	0.20	0.30	--	--	24	30	--	21	25	33
	2100	0.41	0.60	--	26	30	37	--	25	30	37
	2425	0.55	0.81	*	29	33	39	*	27	31	39
	2900	0.79	1.16	*	32	36	43	*	29	34	41
16	1200	0.11	0.15	--	--	21	29	--	--	21	28
	1775	0.24	0.32	--	--	22	31	--	--	24	32
	2350	0.42	0.56	--	22	26	33	--	24	28	35
	2800	0.60	0.80	*	25	29	35	*	27	30	37
	3500	0.93	1.24	*	28	32	39	*	30	33	40

Performance Notes:

- NCs are derived from sound power levels, which are obtained in accordance with AHRI Standard 880-2017 and ASHRAE Standard 130-2016.
- NCs are derived from sound power levels which include duct end corrections per AHRI Standard 880 -2017.
- Blank spaces (--) indicate NCs less than 20.
- Asterisks (*) indicate minimum static pressure of the unit exceeds the minimum operating pressure across the unit.
- ΔPs is the difference in static pressure from inlet to discharge of the unit.
- ΔPs for terminal units with electric coil is equal to basic unit. Resistance of the coil elements is negligible.
- ΔPt is the difference in total pressure from inlet to discharge of the unit.
- NC values are calculated based on typical attenuation values outlined in Appendix E, AHRI Standard 885-2008, "A Procedure for Estimating Occupied Space Sound Levels in the Application of Air Terminals and Air Outlets."

Typical Attenuation Values:

Radiated Sound

Total Deduction	Octave Band Mid Frequency, Hz					
	125	250	500	1000	2000	4000
All Sizes	18	19	20	26	31	36

Discharge Sound

Total Deduction	Octave Band Mid Frequency, Hz					
	125	250	500	1000	2000	4000
< 300 cfm	24	28	39	53	59	40
300-700 cfm	27	29	40	51	53	39
> 700 cfm	29	30	41	51	52	39

PERFORMANCE DATA



DPS / DDS – Standard Mixing Model - Discharge Sound Data

Unit Size	Airflow cfm	Sound Power Levels Lw dB re 10 ⁻¹² Watts																							
		0.5 in.w.g.						1.0 in.w.g.						1.5 in.w.g.						3.0 in.w.g.					
		Octave Band						Octave Band						Octave Band						Octave Band					
	2	3	4	5	6	7	2	3	4	5	6	7	2	3	4	5	6	7	2	3	4	5	6	7	
4	75	51	42	34	23	26	17	53	44	36	24	28	21	53	45	37	25	29	23	55	47	39	27	31	27
	100	56	47	39	28	31	23	57	49	41	30	33	27	58	50	42	31	34	29	59	51	44	32	36	33
	150	63	54	47	36	38	31	64	55	48	38	40	35	65	56	49	39	41	37	66	58	51	40	44	41
	200	68	59	52	42	43	36	69	60	53	43	45	40	70	61	54	44	47	43	71	63	56	46	49	47
	225	*	*	*	*	*	*	71	62	56	46	48	43	72	63	57	47	49	45	73	65	58	48	51	49
5	150	55	46	39	33	32	26	59	50	43	36	37	33	61	52	45	38	39	37	64	56	49	42	44	44
	200	60	50	43	36	36	29	64	54	47	40	40	36	66	56	49	42	43	40	69	60	54	46	47	47
	250	64	54	46	39	39	32	67	57	50	43	43	39	69	60	53	45	46	43	73	63	57	49	50	50
	300	67	56	49	42	41	34	70	60	53	45	46	41	72	62	55	48	48	45	76	66	59	51	53	52
	350	*	*	*	*	*	*	73	63	55	47	47	43	75	65	57	50	50	47	78	69	61	53	55	54
6	200	59	50	42	35	36	32	62	53	46	38	40	38	64	55	48	40	43	41	68	59	52	43	46	47
	250	63	53	46	38	39	35	66	56	50	41	43	41	68	58	52	43	45	44	71	62	56	47	49	50
	300	66	56	49	41	41	37	69	59	53	44	45	43	71	61	55	46	48	47	74	65	59	49	51	53
	350	*	*	*	*	*	*	72	61	56	46	47	46	74	63	58	48	50	49	77	67	61	51	53	55
	400	*	*	*	*	*	*	74	63	58	48	49	47	76	65	60	50	51	51	79	69	64	53	55	57
7	200	55	49	39	32	38	31	59	53	43	35	41	37	61	56	46	37	43	41	66	60	50	40	47	48
	300	61	55	46	38	42	35	66	59	50	42	46	42	68	61	53	43	48	45	72	66	57	47	52	52
	400	66	58	51	43	46	38	70	63	55	46	49	45	73	65	57	48	52	48	77	69	62	51	55	55
	500	70	61	55	47	49	40	74	66	59	50	52	47	77	68	61	52	54	51	81	72	65	55	58	57
	550	*	*	*	*	*	*	76	67	60	52	53	48	78	69	63	54	55	52	82	74	67	57	59	58
8	350	61	54	46	41	43	37	66	59	51	45	48	45	68	62	54	48	50	50	73	67	59	52	55	58
	450	64	56	49	44	45	39	69	62	54	48	49	47	72	65	57	51	52	51	76	70	62	55	57	59
	550	67	59	52	46	46	40	72	64	57	51	51	48	74	67	60	53	54	53	79	72	65	58	59	61
	700	70	61	55	49	48	41	75	66	60	54	53	49	78	69	63	56	56	54	82	74	68	61	60	62
	750	*	*	*	*	*	*	76	67	61	55	53	50	78	70	64	57	56	55	83	75	69	62	61	63
9	400	59	50	42	38	41	36	63	55	47	42	46	44	66	58	49	44	49	49	70	63	54	49	53	56
	550	63	53	48	42	44	39	68	59	52	46	49	47	70	62	54	49	51	51	75	67	59	53	56	59
	700	67	56	52	46	46	41	71	62	56	50	51	48	74	65	58	52	54	53	78	70	63	56	58	60
	900	71	59	56	49	48	43	75	65	60	53	53	50	78	68	63	56	56	55	82	73	67	60	61	62
	1000	*	*	*	*	*	*	77	66	62	55	54	51	79	69	64	57	57	56	84	74	69	61	61	63
10	500	61	51	45	42	44	38	66	56	50	46	49	47	69	59	52	48	51	52	73	64	57	52	56	60
	700	65	55	50	45	46	40	70	60	55	49	51	49	73	63	58	52	54	54	78	68	62	56	58	62
	900	68	58	54	48	48	42	73	63	59	52	52	50	76	66	61	55	55	55	81	71	66	59	60	63
	1100	*	*	*	*	*	*	76	65	62	54	54	51	79	68	64	57	57	56	84	74	69	61	61	65
	1300	*	*	*	*	*	*	78	67	64	56	55	52	81	70	67	58	58	57	86	76	72	62	62	66
12	700	58	50	43	38	43	41	63	56	47	42	48	49	66	59	50	45	51	54	72	65	54	49	56	62
	1000	62	54	50	43	46	43	68	60	54	48	51	51	71	63	57	50	54	56	77	69	61	54	59	64
	1300	66	57	55	47	48	44	72	63	59	51	53	52	75	66	62	54	56	57	80	72	66	58	61	65
	1600	69	59	59	50	50	45	74	65	63	54	55	54	78	68	66	57	58	58	83	74	70	61	63	67
	1900	*	*	*	*	*	*	77	67	67	57	56	54	80	70	69	59	59	59	85	76	73	63	64	68
14	1000	59	51	45	41	46	45	64	57	49	46	51	53	67	60	51	48	53	57	72	66	55	53	58	64
	1475	64	56	53	46	49	47	69	61	57	50	54	55	72	65	59	53	56	59	77	70	63	57	61	66
	2100	69	60	60	50	52	50	74	65	63	54	56	57	77	69	66	57	59	61	82	74	69	61	63	69
	2425	*	*	*	*	*	*	76	67	66	56	57	58	79	70	68	58	60	62	84	76	72	63	64	69
	2900	*	*	*	*	*	*	79	69	70	58	58	59	82	72	72	61	61	63	87	78	76	65	65	70
16	1200	58	51	44	40	45	44	64	57	49	45	50	52	67	60	52	48	53	57	72	65	57	53	58	65
	1775	63	56	51	44	48	46	68	61	56	49	53	54	71	64	58	52	56	59	76	70	63	57	61	67
	2350	66	58	55	47	49	47	71	64	60	53	55	55	74	67	63	56	58	60	79	72	67	61	63	68
	2800	*	*	*	*	*	*	73	66	63	55	56	56	76	69	66	58	59	61	81	74	70	63	64	69
	3500	*	*	*	*	*	*	75	68	67	57	57	57	78	71	69	60	60	62	84	77	74	65	65	70

Performance Notes:

1. Test data obtained in accordance with AHRI Standard 880-2017 and ASHRAE Standard 130-2016.
2. Sound power levels include duct end corrections per AHRI Standard 880-2017.
3. AHRI certified data is highlighted in blue. All other data are application ratings.
4. Application ratings are outside the scope of the AHRI 880 Certification Program.
5. Asterisks (*) indicate minimum static pressure of the unit exceeds the minimum operating pressure across the unit.

PERFORMANCE DATA



DPS, DDS – Standard Mixing Model - Radiated Sound Data

Unit Size	Airflow cfm	Sound Power Levels Lw dB re 10 ⁻¹² Watts																											
		0.5 in.w.g. Octave Band							1.0 in.w.g. Octave Band							1.5 in.w.g. Octave Band							3.0 in.w.g. Octave Band						
		2	3	4	5	6	7	2	3	4	5	6	7	2	3	4	5	6	7	2	3	4	5	6	7				
4	75	44	34	30	23	20	--	44	36	32	26	25	22	44	37	33	28	28	27	45	38	35	32	33	35				
	100	46	37	34	26	22	--	47	39	36	30	28	23	47	40	37	32	31	28	47	41	39	36	36	36				
	150	50	41	40	31	26	17	50	43	42	35	31	25	50	44	43	37	34	30	51	45	45	40	40	38				
	200	52	44	43	34	29	18	53	46	46	38	34	26	53	47	47	40	37	31	53	48	49	44	42	39				
	225	*	*	*	*	*	*	54	47	47	39	35	27	54	48	48	42	38	32	54	49	50	45	43	40				
5	150	46	37	34	25	21	--	48	40	38	30	27	23	49	42	40	32	30	27	51	44	44	36	35	35				
	200	49	40	37	28	24	17	51	43	41	32	29	25	52	44	43	35	32	29	54	47	47	39	37	36				
	250	51	42	39	30	25	18	53	45	43	34	31	26	55	47	45	37	34	30	57	49	49	41	39	37				
	300	53	44	41	32	27	19	55	47	45	36	32	27	57	48	47	38	35	31	59	51	51	43	41	38				
	350	*	*	*	*	*	*	57	48	47	37	33	27	58	50	49	40	36	32	60	53	53	44	42	39				
6	200	44	37	32	26	22	--	47	40	37	31	28	23	48	42	40	34	31	27	50	46	45	39	36	34				
	250	48	39	34	27	23	--	50	43	39	32	29	24	51	45	42	35	32	28	54	49	48	40	37	35				
	300	51	41	36	28	24	18	53	45	41	33	30	25	54	47	44	36	33	29	57	51	49	41	38	35				
	350	*	*	*	*	*	*	55	47	43	34	30	25	57	49	46	37	34	29	59	52	51	42	39	36				
	400	*	*	*	*	*	*	57	48	44	35	31	26	59	50	47	38	34	30	61	54	52	43	40	37				
7	200	42	34	28	25	21	--	45	38	33	30	26	21	47	41	36	32	30	26	50	45	41	37	35	35				
	300	49	39	33	29	25	--	52	43	38	33	30	24	54	46	41	36	33	29	57	50	46	41	38	38				
	400	53	42	36	31	27	17	57	47	41	36	33	26	58	49	44	39	36	31	61	53	49	43	41	40				
	500	57	45	39	33	29	19	60	49	44	38	35	28	62	52	47	41	38	33	65	56	52	45	43	42				
	550	*	*	*	*	*	*	62	51	45	39	35	28	64	53	48	41	38	34	67	57	53	46	44	42				
8	350	50	40	34	29	25	21	53	45	40	35	30	27	55	48	43	38	33	30	59	52	49	43	39	35				
	450	54	43	37	31	27	24	57	47	42	36	32	29	59	50	46	39	35	32	62	55	51	45	40	38				
	550	56	45	39	32	28	26	60	50	44	38	34	31	62	52	47	41	37	35	65	57	53	46	42	40				
	700	60	47	41	34	30	29	63	52	46	39	35	34	65	55	50	42	38	37	68	60	55	48	44	42				
	750	*	*	*	*	*	*	64	53	47	40	36	35	66	56	50	43	39	38	69	60	56	48	44	43				
9	400	49	37	32	28	25	19	53	44	37	33	30	28	56	48	41	35	33	33	61	55	46	40	39	41				
	550	52	40	36	31	27	21	57	47	41	35	32	29	60	51	44	38	36	34	64	57	50	43	41	43				
	700	55	42	38	33	28	22	59	49	44	38	34	30	62	53	47	40	37	35	67	59	52	45	43	44				
	900	57	44	41	35	30	23	62	51	47	40	36	32	65	55	50	42	39	37	70	61	55	47	44	45				
	1000	*	*	*	*	*	*	63	52	48	41	36	32	66	56	51	43	39	37	71	62	56	48	45	46				
10	500	49	40	35	29	26	20	54	46	40	35	32	29	57	50	44	38	36	34	62	57	49	43	42	43				
	700	52	42	39	32	28	22	57	49	44	37	34	30	60	52	47	40	37	35	65	59	53	46	43	44				
	900	55	44	41	33	29	23	60	50	47	39	35	31	63	54	50	42	38	36	68	61	56	47	44	45				
	1100	*	*	*	*	*	*	62	52	49	40	36	32	65	56	52	43	39	37	70	62	58	49	45	46				
	1300	*	*	*	*	*	*	64	53	51	41	36	33	67	57	54	44	40	38	72	64	60	50	46	47				
12	700	48	39	35	26	24	20	53	46	39	31	30	28	56	49	41	35	34	33	61	56	46	40	40	41				
	1000	51	43	39	31	27	22	57	49	43	36	33	30	60	52	46	39	36	35	65	59	50	44	42	43				
	1300	54	45	42	34	28	24	60	51	47	39	34	32	63	55	49	42	38	37	68	61	53	48	44	45				
	1600	56	47	45	37	30	25	62	53	49	42	36	33	65	57	52	45	39	38	70	63	56	50	45	46				
	1900	*	*	*	*	*	*	64	54	51	44	37	34	67	58	54	47	40	39	72	64	58	53	46	47				
14	1000	49	42	36	31	29	23	55	49	41	36	34	31	58	52	44	39	37	35	64	58	49	44	42	43				
	1475	53	46	40	34	31	25	59	52	45	39	36	33	62	55	49	42	39	37	68	62	54	47	44	45				
	2100	57	48	44	37	33	27	62	55	49	42	38	34	66	58	53	45	41	39	71	64	58	50	46	46				
	2425	*	*	*	*	*	*	64	56	51	43	39	35	67	59	54	46	42	39	73	66	60	51	47	47				
	2900	*	*	*	*	*	*	65	57	53	45	40	36	69	61	56	48	43	40	75	67	62	53	48	48				
16	1200	49	42	35	29	25	22	54	49	40	34	30	29	57	52	43	37	32	33	63	59	48	42	37	39				
	1775	53	45	41	33	30	27	58	51	46	38	35	33	61	55	49	41	37	37	67	62	54	46	42	44				
	2350	55	47	45	36	33	30	61	53	50	41	38	37	64	57	53	44	41	41	70	64	58	49	46	47				
	2800	*	*	*	*	*	*	63	55	52	43	40	39	66	58	55	46	43	43	72	65	61	51	48	49				
	3500	*	*	*	*	*	*	65	56	55	45	43	41	68	60	59	48	46	45	74	66	64	53	51	52				

Performance Notes:

- Test data obtained in accordance with AHRI Standard 880-2017 and ASHRAE Standard 130-2016.
- Sound power levels include duct end corrections per AHRI Standard 880-2017.
- AHRI certified data is highlighted in blue. All other data are application ratings.
- Application ratings are outside the scope of the AHRI 880 Certification Program.
- Asterisks (*) indicate minimum static pressure of the unit exceeds the minimum operating pressure across the unit.
- Dashes (-) indicate sound power levels below 36-29-26-22-19-17 for each octave band; values below these sound power levels are considered below significance per AHRI 880.

PERFORMANCE DATA

DPS / DDS - Standard Mixing Model - Typical Selection Guide

Aluminum Foil Lined Construction, CRAF - No Lined Ductwork

Unit Size	Airflow cfm	Min. ΔPs Across Unit		Discharge NC ΔPs Across Unit				Radiated NC ΔPs Across Unit			
		in.w.g.	in.w.g.	0.5 in.w.g.	1.0 in.w.g.	1.5 in.w.g.	3.0 in.w.g.	0.5 in.w.g.	1.0 in.w.g.	1.5 in.w.g.	3.0 in.w.g.
4	75	0.07	0.12	—	—	—	—	—	—	—	—
	100	0.12	0.20	—	—	—	—	—	—	—	—
	150	0.26	0.44	23	25	26	28	—	—	—	—
	200	0.47	0.79	30	31	32	34	—	—	21	23
	225	0.59	1.00	*	34	35	36	*	21	22	25
5	150	0.12	0.19	—	—	22	28	—	—	—	—
	200	0.21	0.34	—	24	27	32	—	—	—	21
	250	0.32	0.52	25	29	32	36	—	—	—	23
	300	0.46	0.75	25	29	32	36	—	—	21	25
	350	0.63	1.03	*	32	35	40	*	21	23	27
6	200	0.18	0.24	—	23	26	31	—	—	—	—
	250	0.28	0.37	23	28	30	34	—	—	—	21
	300	0.40	0.53	23	28	30	34	—	—	—	23
	350	0.54	0.72	*	31	33	38	*	—	—	25
	400	0.71	0.95	*	34	36	41	*	—	21	27
7	200	0.08	0.11	—	22	26	32	—	—	—	—
	300	0.17	0.24	—	24	27	33	—	—	—	—
	400	0.31	10.44	24	29	33	38	—	—	20	24
	500	0.48	0.68	29	34	37	43	—	23	25	29
	550	0.58	0.82	*	36	39	45	*	25	27	31
8	350	0.14	0.19	—	26	31	39	—	—	—	23
	450	0.23	0.32	21	28	33	41	—	—	21	25
	550	0.35	0.48	25	31	34	42	—	22	25	29
	700	0.57	0.78	29	35	39	45	22	26	29	33
	750	0.65	0.89	*	34	37	43	*	28	30	34
9	400	0.10	0.14	—	26	30	38	—	—	—	24
	550	0.19	0.27	21	28	32	40	—	—	22	28
	700	0.31	0.45	25	31	34	42	—	22	25	31
	900	0.52	0.74	27	33	36	42	—	25	29	35
	1000	0.64	0.92	*	35	38	44	*	27	30	36
10	500	0.11	0.15	20	28	33	41	—	—	—	26
	700	0.22	0.30	23	30	35	43	—	—	23	29
	900	0.36	0.50	24	30	34	43	—	23	26	33
	1100	0.54	0.74	*	34	37	44	*	25	29	35
	1300	0.75	1.03	*	37	40	46	*	28	31	38
12	700	0.09	0.13	23	31	35	43	—	—	—	25
	1000	0.19	0.27	22	30	35	43	—	—	22	29
	1300	0.31	0.44	24	32	37	45	—	22	26	33
	1600	0.48	0.68	25	33	38	46	—	25	29	35
	1900	0.67	0.95	*	35	39	47	*	27	31	38
14	1000	0.09	0.13	25	32	36	43	—	—	21	28
	1475	0.20	0.30	27	34	38	46	—	21	25	33
	2100	0.41	0.60	29	36	40	48	—	25	30	37
	2425	0.55	0.81	*	37	41	49	*	27	31	39
	2900	0.79	1.16	*	38	42	50	*	29	34	41
16	1200	0.11	0.15	23	32	36	44	—	—	21	28
	1775	0.24	0.32	25	33	38	46	—	—	24	32
	2350	0.42	0.56	27	35	39	48	—	24	28	35
	2800	0.60	0.80	*	36	40	48	*	27	30	37
	3500	0.93	1.24	*	37	41	49	*	30	33	40

Performance Notes:

- NCs are derived from sound power levels, which are obtained in accordance with AHRI Standard 880-2017 and ASHRAE Standard 130-2016.
- NCs are derived from sound power levels which include duct end corrections per AHRI Standard 880 -2017.
- Blank spaces (--) indicate NCs less than 20.
- Asterisks (*) indicate minimum static pressure of the unit exceeds the minimum operating pressure across the unit.
- ΔPs is the difference in static pressure from inlet to discharge of the unit.
- ΔPs for terminal units with electric coil is equal to basic unit. Resistance of the coil elements is negligible.
- ΔPt is the difference in total pressure from inlet to discharge of the unit.
- NC values are calculated based on procedures outlined in AHRI Standard 885- 2008, "A Procedure for Estimating Occupied Space Sound Levels in the Application of Air Terminals and Air Outlets."

Radiated Sound is based on a 5/8 in. mineral fiber tile ceiling per AHRI 885-2008, Appendix E typical attenuation values.

Total Deduction	Octave Band Mid Frequency, Hz					
	125	250	500	1000	2000	4000
All Sizes	18	19	20	26	31	36

Discharge Sound is based on environmental effect, end reflection, flex duct effect, space effect, and sound power division. No deductions for lined duct are included. These calculations are not covered by AHRI 885-2008 Appendix E.

Total Deduction	Octave Band Mid Frequency, Hz					
	125	250	500	1000	2000	4000
< 300 cfm	22	22	27	28	30	22
300-700 cfm	25	25	30	31	33	25
> 700 cfm	27	27	32	33	35	27

DUAL DUCT

Terminal Units

PERFORMANCE DATA

DPS / DDS - Standard Mixing Model - Discharge Sound Data

Aluminum Foil Lined Construction, CRAF

Unit Size	Airflow cfm	Sound Power Levels Lw dB re 10 ⁻¹² Watts																											
		0.5 in.w.g.							1.0 in.w.g.							1.5 in.w.g.							3.0 in.w.g.						
		Octave Band							Octave Band							Octave Band							Octave Band						
4	35	53	44	35	26	31	21	55	46	37	27	33	25	55	47	38	28	34	27	57	49	40	30	36	31				
	47	58	49	40	31	36	27	59	51	42	33	38	31	60	52	43	34	39	33	61	53	45	35	41	37				
	71	65	56	48	39	43	35	66	57	49	41	45	39	67	58	50	42	46	41	68	60	52	43	49	45				
	94	70	61	53	45	48	40	71	62	54	46	50	44	72	63	55	47	52	47	73	65	57	49	54	51				
	106	*	*	*	*	*	*	73	64	57	49	53	47	74	65	58	50	54	49	75	67	59	51	56	53				
5	71	57	48	40	36	37	30	61	52	44	39	42	37	63	54	46	41	44	41	66	58	50	45	49	48				
	94	62	52	44	39	41	33	66	56	48	43	45	40	68	58	50	45	48	44	71	62	55	49	52	51				
	118	66	56	47	42	44	36	69	59	51	46	48	43	71	62	54	48	51	47	75	65	58	52	55	54				
	142	69	58	50	45	46	38	72	62	54	48	51	45	74	64	56	51	53	49	78	68	60	54	58	56				
	165	*	*	*	*	*	*	75	65	56	50	52	47	77	67	58	53	55	51	80	71	62	56	60	58				
6	94	61	52	43	38	41	36	64	55	47	41	45	42	66	57	49	43	48	45	70	61	53	46	51	51				
	118	65	55	47	41	44	39	68	58	51	44	48	45	70	60	53	46	50	48	73	64	57	50	54	54				
	142	68	58	50	44	46	41	71	61	54	47	50	47	73	63	56	49	53	51	76	67	60	52	56	57				
	165	*	*	*	*	*	*	74	63	57	49	52	50	76	65	59	51	55	53	79	69	62	54	58	59				
	189	*	*	*	*	*	*	76	65	59	51	54	51	78	67	61	53	56	55	81	71	65	56	60	61				
7	94	57	51	40	35	43	35	61	55	44	38	46	41	63	58	47	40	48	45	68	62	51	43	52	52				
	142	63	57	47	41	47	39	68	61	51	45	51	46	70	63	54	46	53	49	74	68	58	50	57	56				
	189	68	60	52	46	51	42	72	65	56	49	54	49	75	67	58	51	57	52	79	71	63	54	60	59				
	236	72	63	56	50	54	44	76	68	60	53	57	51	79	70	62	55	59	55	83	74	66	58	63	61				
	260	*	*	*	*	*	*	78	69	61	55	58	52	80	71	64	57	60	56	84	76	68	60	64	62				
8	165	63	56	47	44	48	41	68	61	52	48	53	49	70	64	55	51	55	54	75	69	60	55	60	62				
	212	66	58	50	47	50	43	71	64	55	51	54	51	74	67	58	54	57	55	78	72	63	58	62	63				
	260	69	61	53	49	51	44	74	66	58	54	56	52	76	69	61	56	59	57	81	74	66	61	64	65				
	330	72	63	56	52	53	45	77	68	61	57	58	53	80	71	64	59	61	58	84	76	69	64	65	66				
	354	*	*	*	*	*	*	78	69	62	58	58	54	80	72	65	60	61	59	85	77	70	65	66	67				
9	189	61	52	43	41	46	40	65	57	48	45	51	48	68	60	50	47	54	53	72	65	55	52	58	60				
	260	65	55	49	45	49	43	70	61	53	49	54	51	72	64	55	52	56	55	77	69	60	56	61	63				
	330	69	58	53	49	51	45	73	64	57	53	56	52	76	67	59	55	59	57	80	72	64	59	63	64				
	425	73	61	57	52	53	47	77	67	61	56	58	54	80	70	64	59	61	59	84	75	68	63	66	66				
	472	*	*	*	*	*	*	79	68	63	58	59	55	81	71	65	60	62	60	86	76	70	64	66	67				
10	236	63	53	46	45	49	42	68	58	51	49	54	51	71	61	53	51	56	56	75	66	58	55	61	64				
	330	67	57	51	48	51	44	72	62	56	52	56	53	75	65	59	55	59	58	80	70	63	59	63	66				
	425	70	60	55	51	53	46	75	65	60	55	57	54	78	68	62	58	60	59	83	73	67	62	65	67				
	519	*	*	*	*	*	*	78	67	63	57	59	55	81	70	65	60	62	60	86	76	70	64	66	69				
	614	*	*	*	*	*	*	80	69	65	59	60	56	83	72	68	61	63	61	88	78	73	65	67	70				
12	330	60	52	44	41	48	45	65	58	48	45	53	53	68	61	51	48	56	58	74	67	55	52	61	66				
	472	64	56	51	46	51	47	70	62	55	51	56	55	73	65	58	53	59	60	79	71	62	57	64	68				
	614	68	59	56	50	53	48	74	65	60	54	58	56	77	68	63	57	61	61	82	74	67	61	66	69				
	755	71	61	60	53	55	49	76	67	64	57	60	58	80	70	67	60	63	62	85	76	71	64	68	71				
	897	*	*	*	*	*	*	79	69	68	60	61	58	82	72	70	62	64	63	87	78	74	66	69	72				
14	472	61	53	46	44	51	49	66	59	50	49	56	57	69	62	52	51	58	61	74	68	56	56	63	68				
	696	66	58	54	49	54	51	71	63	58	53	59	59	74	67	60	56	61	63	79	72	64	60	66	70				
	991	71	62	61	53	57	54	76	67	64	57	61	61	79	71	67	60	64	65	84	76	70	64	68	73				
	1144	*	*	*	*	*	*	78	69	67	59	62	62	81	72	69	61	65	66	86	78	73	66	69	73				
	1369	*	*	*	*	*	*	81	71	71	61	63	63	84	74	73	64	66	67	89	80	77	68	70	74				
16	566	60	53	45	43	50	48	66	59	50	48	55	56	69	62	53	51	58	61	74	67	58	56	63	69				
	838	65	58	52	47	53	50	70	63	57	52	58	58	73	66	59	55	61	63	78	72	64	60	66	71				
	1109	68	60	56	50	54	51	73	66	61	56	60	59	76	69	64	59	63	64	81	74	68	64	68	72				
	1321	*	*	*	*	*	*	75	68	64	58	61	60	78	71	67	61	64	65	83	76	71	66	69	73				
	1652	*	*	*	*	*	*	77	70	68	60	62	61	80	73	70	63	65	66	86	79	75	68	70	74				

Performance Notes:

- Test data obtained in accordance with AHRI Standard 880-2017 and ASHRAE Standard 130-2016.
- Sound power levels include duct end corrections per AHRI Standard 880-2017.
- Airflow given in cfm.
- Pressure is given in in.w.g.
- All data are application ratings. Application ratings are outside the scope of the AHRI 880 Certification Program.
- Asterisks (*) indicate minimum static pressure of the unit exceeds the minimum operating pressure across the unit.

PERFORMANCE DATA



DPS / DDS - Standard Mixing Model - Radiated Sound Data

Aluminum Foil Lined Construction, CRAF

Unit Size	Airflow cfm	Sound Power Levels Lw dB re 10 ⁻¹² Watts																											
		0.5 in.w.g.						1.0 in.w.g.						1.5 in.w.g.						3.0 in.w.g.									
		Octave Band						Octave Band						Octave Band						Octave Band									
		2	3	4	5	6	7	2	3	4	5	6	7	2	3	4	5	6	7	2	3	4	5	6	7				
4	75	44	34	30	23	20	--	44	36	32	26	25	22	44	37	33	28	28	27	45	38	35	32	33	35				
	100	46	37	34	26	22	--	47	39	36	30	28	23	47	40	37	32	31	28	47	41	39	36	36	36				
	150	50	41	40	31	26	17	50	43	42	35	31	25	50	44	43	37	34	30	51	45	45	40	40	38				
	200	52	44	43	34	29	18	53	46	46	38	34	26	53	47	47	40	37	31	53	48	49	44	42	39				
	225	*	*	*	*	*	*	54	47	47	39	35	27	54	48	48	42	38	32	54	49	50	45	43	40				
5	150	46	37	34	25	21	--	48	40	38	30	27	23	49	42	40	32	30	27	51	44	44	36	35	35				
	200	49	40	37	28	24	17	51	43	41	32	29	25	52	44	43	35	32	29	54	47	47	39	37	36				
	250	51	42	39	30	25	18	53	45	43	34	31	26	55	47	45	37	34	30	57	49	49	41	39	37				
	300	53	44	41	32	27	19	55	47	45	36	32	27	57	48	47	38	35	31	59	51	51	43	41	38				
	350	*	*	*	*	*	*	57	48	47	37	33	27	58	50	49	40	36	32	60	53	53	44	42	39				
6	200	44	37	32	26	22	--	47	40	37	31	28	23	48	42	40	34	31	27	50	46	45	39	36	34				
	250	48	39	34	27	23	--	50	43	39	32	29	24	51	45	42	35	32	28	54	49	48	40	37	35				
	300	51	41	36	28	24	18	53	45	41	33	30	25	54	47	44	36	33	29	57	51	49	41	38	35				
	350	*	*	*	*	*	*	55	47	43	34	30	25	57	49	46	37	34	29	59	52	51	42	39	36				
	400	*	*	*	*	*	*	57	48	44	35	31	26	59	50	47	38	34	30	61	54	52	43	40	37				
7	200	42	34	28	25	21	--	45	38	33	30	26	21	47	41	36	32	30	26	50	45	41	37	35	35				
	300	49	39	33	29	25	--	52	43	38	33	30	24	54	46	41	36	33	29	57	50	46	41	38	38				
	400	53	42	36	31	27	17	57	47	41	36	33	26	58	49	44	39	36	31	61	53	49	43	41	40				
	500	57	45	39	33	29	19	60	49	44	38	35	28	62	52	47	41	38	33	65	56	52	45	43	42				
	550	*	*	*	*	*	*	62	51	45	39	35	28	64	53	48	41	38	34	67	57	53	46	44	42				
8	350	50	40	34	29	25	21	53	45	40	35	30	27	55	48	43	38	33	30	59	52	49	43	39	35				
	450	54	43	37	31	27	24	57	47	42	36	32	29	59	50	46	39	35	32	62	55	51	45	40	38				
	550	56	45	39	32	28	26	60	50	44	38	34	31	62	52	47	41	37	35	65	57	53	46	42	40				
	700	60	47	41	34	30	29	63	52	46	39	35	34	65	55	50	42	38	37	68	60	55	48	44	42				
	750	*	*	*	*	*	*	64	53	47	40	36	35	66	56	50	43	39	38	69	60	56	48	44	43				
9	400	49	37	32	28	25	19	53	44	37	33	30	28	56	48	41	35	33	33	61	55	46	40	39	41				
	550	52	40	36	31	27	21	57	47	41	35	32	29	60	51	44	38	36	34	64	57	50	43	41	43				
	700	55	42	38	33	28	22	59	49	44	38	34	30	62	53	47	40	37	35	67	59	52	45	43	44				
	900	57	44	41	35	30	23	62	51	47	40	36	32	65	55	50	42	39	37	70	61	55	47	44	45				
	1000	*	*	*	*	*	*	63	52	48	41	36	32	66	56	51	43	39	37	71	62	56	48	45	46				
10	500	49	40	35	29	26	20	54	46	40	35	32	29	57	50	44	38	36	34	62	57	49	43	42	43				
	700	52	42	39	32	28	22	57	49	44	37	34	30	60	52	47	40	37	35	65	59	53	46	43	44				
	900	55	44	41	33	29	23	60	50	47	39	35	31	63	54	50	42	38	36	68	61	56	47	44	45				
	1100	*	*	*	*	*	*	62	52	49	40	36	32	65	56	52	43	39	37	70	62	58	49	45	46				
	1300	*	*	*	*	*	*	64	53	51	41	36	33	67	57	54	44	40	38	72	64	60	50	46	47				
12	700	48	39	35	26	24	20	53	46	39	31	30	28	56	49	41	35	34	33	61	56	46	40	40	41				
	1000	51	43	39	31	27	22	57	49	43	36	33	30	60	52	46	39	36	35	65	59	50	44	42	43				
	1300	54	45	42	34	28	24	60	51	47	39	34	32	63	55	49	42	38	37	68	61	53	48	44	45				
	1600	56	47	45	37	30	25	62	53	49	42	36	33	65	57	52	45	39	38	70	63	56	50	45	46				
	1900	*	*	*	*	*	*	64	54	51	44	37	34	67	58	54	47	40	39	72	64	58	53	46	47				
14	1000	49	42	36	31	29	23	55	49	41	36	34	31	58	52	44	39	37	35	64	58	49	44	42	43				
	1475	53	46	40	34	31	25	59	52	45	39	36	33	62	55	49	42	39	37	68	62	54	47	44	45				
	2100	57	48	44	37	33	27	62	55	49	42	38	34	66	58	53	45	41	39	71	64	58	50	46	46				
	2425	*	*	*	*	*	*	64	56	51	43	39	35	67	59	54	46	42	39	73	66	60	51	47	47				
	2900	*	*	*	*	*	*	65	57	53	45	40	36	69	61	56	48	43	40	75	67	62	53	48	48				
16	1200	49	42	35	29	25	22	54	49	40	34	30	29	57	52	43	37	32	33	63	59	48	42	37	39				
	1775	53	45	41	33	30	27	58	51	46	38	35	33	61	55	49	41	37	37	67	62	54	46	42	44				
	2350	55	47	45	36	33	30	61	53	50	41	38	37	64	57	53	44	41	41	70	64	58	49	46	47				
	2800	*	*	*	*	*	*	63	55	52	43	40	39	66	58	55	46	43	43	72	65	61	51	48	49				
	3500	*	*	*	*	*	*	65	56	55	45	43	41	68	60	59	48	46	45	74	66	64	53	51	52				

Performance Notes:

- Test data obtained in accordance with AHRI Standard 880-2017 and ASHRAE Standard 130-2016.
- Sound power levels include duct end corrections per AHRI Standard 880-2017.
- AHRI certified data is highlighted in blue. All other data are application ratings.
- Application ratings are outside the scope of the AHRI 880 Certification Program.
- Asterisks (*) indicate minimum static pressure of the unit exceeds the minimum operating pressure across the unit.
- Dashes (-) indicate sound power levels below 36-29-26-22-19-17 for each octave band; values below these sound power levels are considered below significance per AHRI 880.

PERFORMANCE DATA

DPQ / DDQ – Standard Mixing Quiet Model - Typical Selection Guide

Unit Size	Airflow	Min. ΔPs Across Unit	Min. ΔPt.	Discharge NC ΔPs Across Unit				Radiated NC ΔPs Across Unit			
	cfm	in.w.g	in.w.g	0.5 in.w.g	1.0 in.w.g	1.5 in.w.g	3.0 in.w.g	0.5 in.w.g	1.0 in.w.g	1.5 in.w.g	3.0 in.w.g
4	75	0.06	0.11	--	--	--	--	--	--	--	--
	100	0.10	0.18	--	--	--	--	--	--	--	--
	150	0.23	0.41	--	--	--	--	--	--	--	21
	200	0.40	0.72	--	--	--	--	--	--	21	25
	225	0.51	0.92	*	--	--	--	--	*	21	23
5	150	0.10	0.17	--	--	--	--	--	--	--	--
	200	0.19	0.32	--	--	--	23	--	--	--	20
	250	0.29	0.49	--	21	23	27	--	--	--	23
	300	0.42	0.71	--	20	23	26	--	--	21	25
	350	0.57	0.97	*	23	25	29	*	22	23	27
6	200	0.16	0.22	--	--	--	21	--	--	--	--
	250	0.28	0.37	--	--	22	26	--	--	--	22
	300	0.36	0.49	--	--	22	26	--	--	--	24
	350	0.49	0.67	--	22	25	29	--	21	23	26
	400	0.64	0.88	*	25	27	32	*	23	25	28
7	200	0.07	0.10	--	--	--	--	--	--	--	--
	300	0.16	0.23	--	--	--	22	--	--	--	21
	400	0.28	0.41	--	20	23	28	--	--	20	25
	500	0.43	0.63	--	25	28	33	--	23	25	29
	550	0.52	0.76	*	27	30	35	*	25	27	31
8	350	0.12	0.17	--	--	--	25	--	--	--	26
	450	0.20	0.29	--	--	23	30	--	--	22	28
	550	0.31	0.44	--	23	27	33	--	21	24	30
	700	0.50	0.71	21	27	31	37	21	25	28	32
	750	0.57	0.81	*	26	30	36	*	26	29	34
9	400	0.08	0.12	--	--	--	22	--	--	--	26
	550	0.16	0.24	--	--	23	28	--	--	22	29
	700	0.26	0.40	--	24	27	33	--	22	25	31
	900	0.43	0.65	20	26	29	35	--	25	29	34
	1000	0.53	0.81	*	28	31	37	*	27	30	36
10	500	0.09	0.13	--	--	--	23	--	--	22	29
	700	0.19	0.27	--	20	24	29	--	21	24	31
	900	0.31	0.45	--	22	26	32	--	24	27	32
	1100	0.46	0.66	21	26	30	35	22	27	29	34
	1300	0.64	0.92	*	29	33	38	*	29	32	36
12	700	0.08	0.12	--	--	--	24	--	--	--	27
	1000	0.16	0.24	--	--	22	28	--	--	23	31
	1300	0.28	0.41	--	23	27	33	--	22	26	34
	1600	0.42	0.62	21	27	31	37	--	25	29	37
	1900	0.60	0.88	*	30	34	40	*	27	32	39
14	1000	0.10	0.14	--	--	--	22	--	--	23	30
	1475	0.21	0.31	--	--	21	27	--	23	28	35
	2100	0.43	0.62	--	23	26	33	20	28	32	40
	2425	0.57	0.83	*	25	29	35	*	30	34	41
	2900	0.81	1.18	*	28	32	38	*	32	36	44
16	1200	0.11	0.15	--	--	20	27	--	--	23	31
	1775	0.23	0.31	--	--	22	29	--	22	27	34
	2350	0.40	0.54	--	20	24	31	--	26	30	37
	2800	0.57	0.77	*	21	25	32	*	29	33	40
	3500	0.89	1.20	*	23	27	34	*	32	35	42

Performance Notes:

- NCs are derived from sound power levels, which are obtained in accordance with AHRI Standard 880-2017 and ASHRAE Standard 130-2016.
- NCs are derived from sound power levels which include duct end corrections per AHRI Standard 880-2017.
- Blank spaces (-) indicate NCs less than 20.
- Asterisks (*) indicate minimum static pressure of the unit exceeds the minimum operating pressure across the unit.
- ΔPs is the difference in static pressure from inlet to discharge of the unit.
- ΔPs for terminal units with electric coil is equal to basic unit. Resistance of the coil elements is negligible.
- ΔPt is the difference in total pressure from inlet to discharge of the unit.
- NC values are calculated based on typical attenuation values outlined in Appendix E, AHRI Standard 885-2008, "A Procedure for Estimating Occupied Space Sound Levels in the Application of Air Terminals and Air Outlets."

Typical Attenuation Values:

Radiated Sound

Total Deduction	Octave Band Mid Frequency, Hz					
	120	250	500	1000	2000	4000
All Sizes	18	19	20	26	31	36

Discharge Sound

Total Deduction	Octave Band Mid Frequency, Hz					
	120	250	500	1000	2000	4000
< 300 cfm	24	28	39	53	59	40
300-700 cfm	27	29	40	51	53	39
> 700 cfm	29	30	41	51	52	39

DUAL DUCT

Terminal Units

PERFORMANCE DATA

DPQ / DDQ – Standard Mixing Quiet Model - Discharge Sound Data

Unit Size	Airflow cfm	Sound Power Levels Lw dB re 10 ⁻¹² Watts																											
		0.5 in.w.g.							1.0 in.w.g.							1.5 in.w.g.							3.0 in.w.g.						
		Octave Band							Octave Band							Octave Band							Octave Band						
		2	3	4	5	6	7	2	3	4	5	6	7	2	3	4	5	6	7	2	3	4	5	6	7				
4	75	53	43	33	22	19	17	55	46	36	22	19	17	57	48	38	22	20	18	60	51	41	25	23	21				
	100	54	44	34	22	19	17	56	47	38	22	20	17	58	49	40	24	21	19	61	52	43	27	23	22				
	150	55	46	36	22	19	17	58	49	40	24	21	17	60	51	42	26	22	19	62	54	45	28	24	22				
	200	56	47	38	23	19	17	59	50	41	26	21	18	61	52	43	27	23	19	63	55	46	30	25	22				
	225	*	*	*	*	*	*	59	51	42	26	22	18	61	52	44	28	23	20	64	55	47	30	25	23				
5	150	56	45	33	22	19	17	59	48	37	22	19	17	60	50	40	25	20	17	63	53	44	28	24	22				
	200	59	49	37	23	19	17	62	52	42	26	21	17	64	54	44	29	23	18	67	57	48	32	27	24				
	250	62	52	41	26	19	17	65	55	45	30	23	17	67	57	47	32	25	20	70	60	51	35	29	25				
	300	65	54	44	29	21	17	67	58	48	32	25	18	69	59	50	34	27	21	72	63	54	38	31	26				
	350	*	*	*	*	*	*	69	60	50	34	26	19	71	62	52	36	29	22	74	65	57	40	33	27				
6	200	57	47	37	22	20	17	60	50	41	25	22	20	62	52	43	27	24	22	65	56	47	30	27	26				
	250	60	50	40	25	21	17	64	53	44	28	24	21	66	56	47	30	26	23	69	59	50	33	28	27				
	300	63	52	43	28	23	18	67	56	47	31	25	22	68	58	49	33	27	24	72	62	53	36	30	28				
	350	66	55	46	30	24	18	69	58	49	33	26	22	71	60	52	35	28	25	74	64	56	38	31	29				
	400	*	*	*	*	*	*	71	60	52	35	27	23	73	62	54	37	29	25	76	66	58	40	32	29				
7	200	52	45	33	22	19	17	56	50	37	22	19	21	58	52	40	24	20	25	62	56	44	27	23	32				
	300	58	51	39	26	19	17	62	55	44	29	22	24	65	58	46	31	24	28	69	62	50	34	28	35				
	400	63	55	44	30	22	19	67	59	48	33	25	26	70	61	51	35	27	30	74	66	55	38	31	37				
	500	67	58	47	33	25	21	71	62	52	37	28	28	73	65	54	38	30	32	77	69	58	42	33	39				
	550	*	*	*	*	*	*	73	63	53	38	29	28	75	66	56	40	31	33	79	70	60	43	34	40				
8	350	58	51	40	28	22	18	63	56	45	32	26	27	66	59	48	35	28	31	71	65	54	40	33	40				
	450	62	54	43	31	23	20	67	59	48	35	28	28	70	62	51	38	30	33	75	67	57	42	34	41				
	550	64	56	45	33	25	21	69	61	51	37	29	29	72	64	54	40	32	34	77	70	59	45	36	42				
	700	68	59	48	36	26	22	73	64	54	40	31	30	76	67	57	43	33	35	81	72	62	47	37	44				
	750	*	*	*	*	*	*	74	65	55	41	31	31	77	68	58	44	34	36	82	73	63	48	38	44				
9	400	58	48	38	26	20	23	62	53	43	29	25	32	65	56	45	32	28	37	69	61	50	36	33	45				
	550	62	52	43	30	23	25	67	57	47	34	28	33	69	60	50	36	30	38	74	65	55	40	35	47				
	700	66	55	46	34	24	26	70	60	51	37	29	35	73	63	54	40	32	39	77	68	58	43	37	48				
	900	69	58	50	37	26	27	74	63	55	41	31	36	76	66	57	43	34	41	81	71	62	47	39	49				
	1000	*	*	*	*	*	*	75	64	56	42	32	36	78	67	59	45	35	41	82	72	63	48	40	50				
10	500	58	48	38	28	22	25	63	53	43	32	28	34	65	56	46	34	31	39	70	61	51	38	36	49				
	700	63	52	43	32	24	26	67	57	48	36	29	35	70	60	51	38	32	41	75	65	55	42	37	50				
	900	67	55	47	34	26	27	71	60	51	38	31	37	74	63	54	41	34	42	78	68	59	45	39	51				
	1100	70	58	50	37	27	28	74	63	54	41	32	37	77	66	57	43	35	43	81	71	62	47	40	52				
	1300	*	*	*	*	*	*	76	65	57	43	33	38	79	68	60	45	36	44	84	73	64	49	41	53				
12	700	58	47	37	25	27	28	63	53	42	30	33	37	66	56	45	32	36	42	71	62	49	37	41	51				
	1000	63	51	43	31	29	30	68	57	47	35	35	38	71	60	50	38	38	44	76	66	55	42	44	53				
	1300	67	54	47	35	31	31	72	60	51	39	37	40	75	63	54	41	40	45	79	69	59	46	45	54				
	1600	70	57	50	38	32	32	75	62	54	42	38	40	77	66	57	45	41	46	82	71	62	49	47	54				
	1900	*	*	*	*	*	*	77	64	57	45	39	41	80	68	60	47	42	46	85	73	65	51	48	55				
14	1000	57	50	40	29	35	37	62	55	44	34	39	45	65	59	47	37	42	50	70	65	51	41	47	58				
	1475	62	54	46	33	37	38	67	60	50	38	42	47	70	63	53	41	45	51	75	69	57	46	49	60				
	2100	67	58	51	37	39	40	71	63	56	42	44	48	74	67	58	45	47	53	79	72	63	49	51	61				
	2425	*	*	*	*	*	*	73	65	58	43	45	48	76	68	60	46	47	53	81	74	65	51	52	61				
	2900	*	*	*	*	*	*	75	67	61	45	46	49	78	70	63	48	48	54	83	76	68	53	53	62				
16	1200	60	54	45	33	38	37	66	60	50	39	44	45	69	63	53	43	47	50	74	69	59	49	52	59				
	1775	62	56	47	35	39	38	68	61	53	41	45	47	71	65	56	45	48	51	76	71	61	51	54	60				
	2350	64	57	49	37	40	39	69	63	55	43	46	47	72	66	58	46	49	52	78	72	63	52	55	61				
	2800	*	*	*	*	*	*	70	64	56	43	46	48	73	67	59	47	50	53	79	73	64	53	55	61				
	3500	*	*	*	*	*	*	71	65	57	45	47	49	74	68	61	48	50	53	80	74	66	54	56	62				

Performance Notes:

1. Test data obtained in accordance with AHRI Standard 880-2017 and ASHRAE Standard 130-2016.
2. Sound power levels include duct end corrections per AHRI Standard 880-2017.
3. Asterisks (*) indicate minimum static pressure of the unit exceeds the minimum operating pressure across the unit.

PERFORMANCE DATA

DPQ / DDQ – Standard Mixing Quiet Model - Radiated Sound Data

Unit Size	Airflow cfm	Sound Power Levels Lw dB re 10 ⁻¹² Watts																											
		0.5 in.w.g. Octave Band							1.0 in.w.g. Octave Band							1.5 in.w.g. Octave Band							3.0 in.w.g. Octave Band						
		2	3	4	5	6	7	2	3	4	5	6	7	2	3	4	5	6	7	2	3	4	5	6	7				
4	75	43	33	31	23	--	--	44	35	34	27	24	17	45	36	36	29	27	23	46	38	39	34	33	33				
	100	46	37	34	26	21	--	47	39	37	30	26	20	48	40	39	32	30	26	49	42	42	37	36	35				
	150	50	42	39	30	24	--	51	44	42	34	30	24	51	45	44	37	34	30	52	47	47	41	39	39				
	200	53	46	43	33	27	17	54	47	46	37	33	27	54	48	47	40	36	33	55	50	51	44	42	42				
	225	*	*	*	*	*	*	55	49	47	39	34	28	55	50	49	41	37	34	56	52	52	45	43	43				
5	150	48	38	33	27	23	17	50	41	37	31	28	24	51	43	39	34	32	28	53	46	43	38	37	35				
	200	51	41	36	29	25	18	53	44	40	34	30	25	54	46	42	36	34	29	56	49	46	41	39	36				
	250	53	44	39	31	27	19	56	47	43	36	32	26	57	48	45	38	35	30	59	51	49	43	41	37				
	300	56	46	41	33	28	20	58	49	45	37	33	27	59	50	47	40	36	31	61	53	51	44	42	37				
	350	*	*	*	*	*	*	59	50	46	39	34	27	61	52	49	41	37	31	63	55	52	46	43	38				
6	200	48	37	32	26	23	--	51	40	37	32	29	24	52	43	41	35	33	28	55	46	46	40	39	36				
	250	51	39	34	27	24	17	54	43	40	33	30	25	55	45	43	36	34	30	58	49	48	42	40	37				
	300	54	41	36	29	25	18	56	45	41	34	31	26	58	47	45	37	35	31	61	51	50	43	41	38				
	350	56	43	38	30	26	19	59	47	43	35	32	27	60	49	46	38	36	31	63	53	51	44	42	39				
	400	*	*	*	*	*	*	60	49	44	36	33	28	62	51	47	39	36	32	65	55	53	45	43	40				
7	200	42	36	30	28	22	--	45	40	35	34	27	23	47	43	37	37	30	28	50	47	42	43	36	37				
	300	49	41	35	31	25	17	52	45	40	36	31	26	54	48	42	40	34	31	57	52	47	45	39	40				
	400	53	45	38	32	27	20	57	49	43	38	33	28	58	51	46	41	36	34	62	56	51	47	42	42				
	500	57	47	41	34	29	21	60	52	46	39	35	30	62	54	49	43	38	35	65	58	54	48	44	44				
	550	*	*	*	*	*	*	62	53	47	40	36	31	64	55	50	43	39	36	67	59	55	49	44	45				
8	350	50	41	37	31	25	--	53	46	42	37	32	25	55	48	46	41	36	31	59	53	52	48	43	42				
	450	53	44	39	32	27	--	57	48	44	38	33	27	59	51	48	42	37	33	62	56	54	49	44	43				
	550	56	46	40	33	28	18	59	50	46	39	34	28	61	53	50	43	38	34	65	58	55	50	45	44				
	700	59	48	42	34	29	20	62	53	48	40	35	30	64	56	51	44	39	36	68	60	57	51	46	46				
	750	*	*	*	*	*	*	63	54	49	41	36	30	65	57	52	44	40	36	69	61	58	51	46	46				
9	400	49	39	34	30	25	19	53	46	39	35	31	28	56	50	42	37	34	33	60	57	48	42	40	41				
	550	52	42	38	33	27	21	57	49	43	37	33	29	59	53	46	40	36	34	64	59	51	45	42	43				
	700	55	44	41	35	29	22	59	51	46	39	34	30	62	55	49	42	38	35	67	61	54	47	43	44				
	900	58	46	44	37	30	23	62	53	49	42	36	31	65	57	52	44	39	37	69	63	57	49	45	45				
	1000	*	*	*	*	*	*	63	54	50	43	37	32	66	58	53	45	40	37	71	64	58	50	46	46				
10	500	52	43	39	33	27	21	55	49	45	39	33	28	57	52	48	43	36	33	60	57	54	50	42	40				
	700	55	46	40	34	28	22	59	51	46	40	34	30	61	55	50	44	38	34	64	60	56	50	43	42				
	900	58	48	42	35	29	24	61	54	48	41	35	31	63	57	51	45	39	36	67	62	57	51	44	43				
	1100	60	50	43	35	30	25	63	55	49	42	36	32	65	58	52	45	39	37	69	64	58	52	45	44				
	1300	*	*	*	*	*	*	65	57	49	42	37	33	67	60	53	46	40	38	71	65	59	52	46	45				
12	700	47	41	35	26	22	19	53	47	40	32	29	27	56	51	42	35	33	32	62	57	46	41	39	41				
	1000	51	44	40	31	25	21	57	50	44	36	32	29	60	54	47	40	35	34	66	61	51	45	42	43				
	1300	54	46	43	34	27	22	60	53	47	39	34	31	63	57	50	43	37	35	69	63	54	49	44	44				
	1600	56	48	46	36	29	23	62	55	50	42	35	32	65	59	52	45	39	37	71	65	57	51	45	45				
	1900	*	*	*	*	*	*	64	56	52	44	36	33	67	60	55	47	40	37	73	67	59	53	47	46				
14	1000	51	44	38	33	30	25	57	51	43	38	35	33	60	54	46	41	38	37	66	60	52	47	44	45				
	1475	55	48	42	36	33	27	61	54	48	41	38	35	64	57	51	44	41	39	70	64	56	50	46	47				
	2100	59	50	46	38	35	29	64	57	51	44	40	36	68	60	55	47	43	41	73	66	60	52	48	48				
	2425	*	*	*	*	*	*	66	58	53	45	41	37	69	61	56	48	44	42	75	68	61	53	49	49				
	2900	*	*	*	*	*	*	67	59	55	46	42	38	71	63	58	49	45	42	77	69	63	55	50	50				
16	1200	51	44	37	31	26	24	56	51	42	36	31	31	59	55	45	39	34	35	65	61	51	44	39	41				
	1775	55	47	42	35	31	29	60	53	48	40	36	35	63	57	51	43	39	39	69	64	56	48	44	46				
	2350	57	49	46	38	35	32	63	55	52	43	40	39	66	59	55	46	42	43	72	66	60	51	47	49				
	2800	*	*	*	*	*	*	65	57	54	45	42	41	68	60	57	48	45	45	73	67	63	53	49	51				
	3500	*	*	*	*	*	*	67	58	57	47	45	43	70	62	60	50	48	47	76	68	66	55	52	54				

Performance Notes:

1. Test data obtained in accordance with AHRI Standard 880-2017 and ASHRAE Standard 130-2016.
2. Sound power levels include duct end corrections per AHRI Standard 880-2017.
3. Asterisks (*) indicate minimum static pressure of the unit exceeds the minimum operating pressure across the unit.
4. Dashes (-) indicate sound power levels below 36-29-26-22-19-17 for each octave band; values below these sound power levels are considered below significance per AHRI 880.

PERFORMANCE DATA

DPQ / DDQ – Standard Mixing Quiet Model - Typical Selection Guide

Aluminum Foil Lined Construction, CRAF - No Lined Ductwork

Unit Size	Airflow cfm	Min. ΔPs Across Unit		Min. ΔPt.	Discharge NC ΔPs Across Unit				Radiated NC ΔPs Across Unit			
		in.w.g.	in.w.g.		0.5 in.w.g.	1.0 in.w.g.	1.5 in.w.g.	3.0 in.w.g.	0.5 in.w.g.	1.0 in.w.g.	1.5 in.w.g.	3.0 in.w.g.
4	75	0.06	0.11	—	—	—	—	—	—	—	—	—
	100	0.10	0.18	—	—	—	21	—	—	—	—	—
	150	0.23	0.41	—	—	—	23	—	—	—	—	21
	200	0.40	0.72	—	—	20	24	—	—	—	21	25
	225	0.51	0.92	*	—	21	25	*	21	23	26	26
5	150	0.10	0.17	—	—	20	24	—	—	—	—	—
	200	0.19	0.32	—	23	25	29	—	—	—	—	20
	250	0.29	0.49	23	26	29	32	—	—	—	—	23
	300	0.42	0.71	22	26	28	31	—	—	—	21	25
	350	0.57	0.97	*	28	30	34	*	22	23	27	27
6	200	0.16	0.22	—	—	22	27	—	—	—	—	—
	250	0.28	0.37	20	24	27	31	—	—	—	—	22
	300	0.36	0.49	20	24	27	31	—	—	—	—	24
	350	0.49	0.67	23	27	30	34	—	21	23	26	26
	400	0.64	0.88	*	30	33	37	*	23	25	28	28
7	200	0.07	0.10	—	—	—	—	—	—	—	—	—
	300	0.16	0.23	—	—	—	25	—	—	—	—	21
	400	0.28	0.41	—	23	26	31	—	—	—	20	25
	500	0.43	0.63	22	27	30	36	—	23	25	29	29
	550	0.52	0.76	*	30	33	38	*	25	27	31	31
8	350	0.12	0.17	—	—	21	28	—	—	—	—	26
	450	0.20	0.29	—	22	26	32	—	—	—	22	28
	550	0.31	0.44	—	25	29	36	—	21	24	30	30
	700	0.50	0.71	23	30	33	40	21	25	28	32	32
	750	0.57	0.81	*	28	32	39	*	26	29	34	34
9	400	0.08	0.12	—	—	—	25	—	—	—	—	26
	550	0.16	0.24	—	22	25	31	—	—	—	22	29
	700	0.26	0.40	21	27	30	36	—	22	25	31	31
	900	0.43	0.65	23	29	32	38	—	25	29	34	34
	1000	0.53	0.81	*	31	34	40	*	27	30	36	36
10	500	0.09	0.13	—	—	—	28	—	—	—	—	29
	700	0.19	0.27	—	23	26	32	—	21	24	31	31
	900	0.31	0.45	—	25	28	34	—	24	27	32	32
	1100	0.46	0.66	23	29	32	38	22	27	29	34	34
	1300	0.64	0.92	*	32	35	41	*	29	32	36	36
12	700	0.08	0.12	—	—	22	31	—	—	—	—	27
	1000	0.16	0.24	—	21	25	31	—	—	—	23	31
	1300	0.28	0.41	—	26	29	36	—	22	26	34	34
	1600	0.42	0.62	23	30	33	40	—	25	29	37	37
	1900	0.60	0.88	*	33	36	43	*	27	32	39	39
14	1000	0.10	0.14	—	23	28	36	—	—	—	23	30
	1475	0.21	0.31	—	24	29	37	—	23	28	35	35
	2100	0.43	0.62	—	25	30	38	20	28	32	40	40
	2425	0.57	0.83	*	28	31	38	*	30	34	41	41
	2900	0.81	1.18	*	31	34	40	*	32	36	44	44
16	1200	0.11	0.15	—	23	28	36	—	—	—	23	31
	1775	0.23	0.31	—	24	29	37	—	22	27	34	34
	2350	0.40	0.54	—	25	30	38	—	26	30	37	37
	2800	0.57	0.77	*	25	30	38	*	29	33	40	40
	3500	0.89	1.20	*	26	31	39	*	32	35	42	42

Performance Notes:

- NCs are derived from sound power levels, which are obtained in accordance with AHRI Standard 880-2017 and ASHRAE Standard 130-2016.
- NCs are derived from sound power levels which include duct end corrections per AHRI Standard 880 -2017.
- Blank spaces (--) indicate NCs less than 20.
- Asterisks (*) indicate minimum static pressure of the unit exceeds the minimum operating pressure across the unit.
- ΔPs is the difference in static pressure from inlet to discharge of the unit.
- ΔPs for terminal units with electric coil is equal to basic unit. Resistance of the coil elements is negligible.
- ΔPt is the difference in total pressure from inlet to discharge of the unit.
- NC values are calculated based on procedures outlined in AHRI Standard 885- 2008, "A Procedure for Estimating Occupied Space Sound Levels in the Application of Air Terminals and Air Outlets."

Radiated Sound is based on a 5/8 in. mineral fiber tile ceiling per AHRI 885-2008, Appendix E typical attenuation values.

Total Deduction	Octave Band Mid Frequency, Hz					
	125	250	500	1000	2000	4000
All Sizes	18	19	20	26	31	36

Discharge Sound is based on environmental effect, end reflection, flex duct effect, space effect, and sound power division. No deductions for lined duct are included. These calculations are not covered by AHRI 885-2008 Appendix E.

Total Deduction	Octave Band Mid Frequency, Hz					
	125	250	500	1000	2000	4000
< 300 cfm	22	22	27	28	30	22
300-700 cfm	25	25	30	31	33	25
> 700 cfm	27	27	32	33	35	27

PERFORMANCE DATA

DPQ / DDQ – Standard Mixing Quiet Model - Discharge Sound Data

Aluminum Foil Lined Construction, CRAF

Unit Size	Airflow cfm	Sound Power Levels Lw dB re 10 ⁻¹² Watts																													
		0.5 in.w.g.							1.0 in.w.g.							1.5 in.w.g.							3.0 in.w.g.								
		Octave Band							Octave Band							Octave Band							Octave Band								
		2	3	4	5	6	7	2	3	4	5	6	7	2	3	4	5	6	7	2	3	4	5	6	7	2	3	4	5	6	7
4	35	53	38	30	--	--	--	55	40	32	--	--	--	55	41	33	--	19	18	57	43	35	--	21	22						
	47	58	43	35	--	21	18	59	45	37	--	23	22	60	46	38	--	24	24	61	47	40	23	26	28						
	71	65	50	43	27	28	26	66	51	44	29	30	30	67	52	45	30	31	32	68	54	47	31	34	36						
	94	70	55	48	33	33	31	71	56	49	34	35	35	72	57	50	35	37	38	73	59	52	37	39	42						
	106	*	*	*	*	*	*	73	58	52	37	38	38	74	59	53	38	39	40	75	61	54	39	41	44						
5	71	57	42	35	24	22	21	61	46	39	27	27	28	63	48	41	29	29	32	66	52	45	33	34	39						
	94	62	46	39	27	26	24	66	50	43	31	30	31	68	52	45	33	33	35	71	56	50	37	37	42						
	118	66	50	42	30	29	27	69	53	46	34	33	34	71	56	49	36	36	38	75	59	53	40	40	45						
	142	69	52	45	33	31	29	72	56	49	36	36	36	74	58	51	39	38	40	78	62	55	42	43	47						
	165	*	*	*	*	*	*	75	59	51	38	37	38	77	61	53	41	40	42	80	65	57	44	45	49						
6	94	61	46	38	26	26	27	64	49	42	29	30	33	66	51	44	31	33	36	70	55	48	34	36	42						
	118	65	49	42	29	29	30	68	52	46	32	33	36	70	54	48	34	35	39	73	58	52	38	39	45						
	142	68	52	45	32	31	32	71	55	49	35	35	38	73	57	51	37	38	42	76	61	55	40	41	48						
	165	*	*	*	*	*	*	74	57	52	37	37	41	76	59	54	39	40	44	79	63	57	42	43	50						
	189	*	*	*	*	*	*	76	59	54	39	39	42	78	61	56	41	41	46	81	65	60	44	45	52						
7	94	55	46	35	26	36	32	59	50	39	29	39	38	61	53	42	31	41	42	66	57	46	34	45	49						
	142	61	52	42	32	40	36	66	56	46	36	44	43	68	58	49	37	46	46	72	63	53	41	50	53						
	189	66	55	47	37	44	39	70	60	51	40	47	46	73	62	53	42	50	49	77	66	58	45	53	56						
	236	70	58	51	41	47	41	74	63	55	44	50	48	77	65	57	46	52	52	81	69	61	49	56	58						
	260	*	*	*	*	*	*	76	64	56	46	51	49	78	66	59	48	53	53	82	71	63	51	57	59						
8	165	61	51	42	35	41	38	66	56	47	39	46	46	68	59	50	42	48	51	73	64	55	46	53	59						
	212	64	53	45	38	43	40	69	59	50	42	47	48	72	62	53	45	50	52	76	67	58	49	55	60						
	260	67	56	48	40	44	41	72	61	53	45	49	49	74	64	56	47	52	54	79	69	61	52	57	62						
	330	70	58	51	43	46	42	75	63	56	48	51	50	78	66	59	50	54	55	82	71	64	55	58	63						
	354	*	*	*	*	*	*	76	64	57	49	51	51	78	67	60	51	54	56	83	72	65	56	59	64						
9	189	59	48	39	33	39	38	63	53	44	37	44	46	66	56	46	39	47	51	70	61	51	44	51	58						
	260	63	51	45	37	42	41	68	57	49	41	47	49	70	60	51	44	49	53	75	65	56	48	54	61						
	330	67	54	49	41	44	43	71	60	53	45	49	50	74	63	55	47	52	55	78	68	60	51	56	62						
	425	71	57	53	44	46	45	75	63	57	48	51	52	78	66	60	51	54	57	82	71	64	55	59	64						
	472	*	*	*	*	*	*	77	64	59	50	52	53	79	67	61	52	55	58	84	72	66	56	59	65						
10	236	61	49	42	37	42	40	66	54	47	41	47	49	69	57	49	43	49	54	73	62	54	47	54	62						
	330	65	53	47	40	44	42	70	58	52	44	49	51	73	61	55	47	52	56	78	66	59	51	56	64						
	425	68	56	51	43	46	44	73	61	56	47	50	52	76	64	58	50	53	57	81	69	63	54	58	65						
	519	*	*	*	*	*	*	76	63	59	49	52	53	79	66	61	52	55	58	84	72	66	56	59	67						
	614	*	*	*	*	*	*	78	65	61	51	53	54	81	68	64	53	56	59	86	74	69	57	60	68						
12	330	58	48	39	32	44	43	63	54	43	36	49	51	66	57	46	39	52	56	72	63	50	43	57	64						
	472	62	52	46	37	47	45	68	58	50	42	52	53	71	61	53	44	55	58	77	67	57	48	60	66						
	614	66	55	51	41	49	46	72	61	55	45	54	54	75	64	58	48	57	59	80	70	62	52	62	67						
	755	69	57	55	44	51	47	74	63	59	48	56	56	78	66	62	51	59	60	83	72	66	55	64	69						
	897	*	*	*	*	*	*	77	65	63	51	57	56	80	68	65	53	60	61	85	74	69	57	65	70						
14	472	59	50	43	37	49	47	64	56	47	42	54	55	67	59	49	44	56	59	72	65	53	49	61	66						
	696	64	55	51	42	52	49	69	60	55	46	57	57	72	64	57	49	59	61	77	69	61	53	64	68						
	991	69	59	58	46	55	52	74	64	61	50	59	59	77	68	64	53	62	63	82	73	67	57	66	71						
	1144	*	*	*	*	*	*	76	66	64	52	60	60	79	69	66	54	63	64	84	75	70	59	67	71						
	1369	*	*	*	*	*	*	79	68	68	54	61	61	82	71	70	57	64	65	87	77	74	61	68	72						
16	566	58	51	42	36	50	46	64	57	47	41	55	54	67	60	50	44	58	59	72	65	55	49	63	67						
	838	63	56	49	40	53	48	68	61	54	45	58	56	71	64	56	48	61	61	76	70	61	53	66	69						
	1109	66	58	53	43	54	49	71	64	58	49	60	57	74	67	61	52	63	62	79	72	65	57	68	70						
	1321	*	*	*	*	*	*	73	66	61	51	61	58	76	69	64	54	64	63	81	74	68	59	69	71						
	1652	*	*	*	*	*	*	75	68	65	53	62	59	78	71	67	56	65	64	84	77	72	61	70	72						

Performance Notes:

1. Test data obtained in accordance with AHRI Standard 880-2017 and ASHRAE Standard 130-2016.
2. Sound power levels include duct end corrections per AHRI Standard 880-2017.
3. Asterisks (*) indicate minimum static pressure of the unit exceeds the minimum operating pressure across the unit.
4. Dashes (-) indicate sound power levels below 36-29-26-22-19-17 for each octave band; values below these sound power levels are considered below significance per AHRI 880.

PERFORMANCE DATA

DPQ / DDQ – Standard Mixing Quiet Model - Radiated Sound Data

Aluminum Foil Lined Construction, CRAF

Unit Size	Airflow cfm	Sound Power Levels Lw dB re 10 ⁻¹² Watts																											
		0.5 in.w.g.						1.0 in.w.g.						1.5 in.w.g.						3.0 in.w.g.									
		Octave Band						Octave Band						Octave Band						Octave Band									
		2	3	4	5	6	7	2	3	4	5	6	7	2	3	4	5	6	7	2	3	4	5	6	7				
4	35	43	33	31	23	--	--	44	35	34	27	24	17	45	36	36	29	27	23	46	38	39	34	33	33				
	47	46	37	34	26	21	--	47	39	37	30	26	20	48	40	39	32	30	26	49	42	42	37	36	35				
	71	50	42	39	30	24	--	51	44	42	34	30	24	51	45	44	37	34	30	52	47	47	41	39	39				
	94	53	46	43	33	27	17	54	47	46	37	33	27	54	48	47	40	36	33	55	50	51	44	42	42				
	106	*	*	*	*	*	*	55	49	47	39	34	28	55	50	49	41	37	34	56	52	52	45	43	43				
5	71	48	38	33	27	23	17	50	41	37	31	28	24	51	43	39	34	32	28	53	46	43	38	37	35				
	94	51	41	36	29	25	18	53	44	40	34	30	25	54	46	42	36	34	29	56	49	46	41	39	36				
	118	53	44	39	31	27	19	56	47	43	36	32	26	57	48	45	38	35	30	59	51	49	43	41	37				
	142	56	46	41	33	28	20	58	49	45	37	33	27	59	50	47	40	36	31	61	53	51	44	42	37				
	165	*	*	*	*	*	*	59	50	46	39	34	27	61	52	49	41	37	31	63	55	52	46	43	38				
6	94	48	37	32	26	23	--	51	40	37	32	29	24	52	43	41	35	33	28	55	46	46	40	39	36				
	118	51	39	34	27	24	17	54	43	40	33	30	25	55	45	43	36	34	30	58	49	48	42	40	37				
	142	54	41	36	29	25	18	56	45	41	34	31	26	58	47	45	37	35	31	61	51	50	43	41	38				
	165	*	*	*	*	*	*	59	47	43	35	32	27	60	49	46	38	36	31	63	53	51	44	42	39				
	189	*	*	*	*	*	*	60	49	44	36	33	28	62	51	47	39	36	32	65	55	53	45	43	40				
7	94	42	36	30	28	22	--	45	40	35	34	27	23	47	43	37	37	30	28	50	47	42	43	36	37				
	142	49	41	35	31	25	17	52	45	40	36	31	26	54	48	42	40	34	31	57	52	47	45	39	40				
	189	53	45	38	32	27	20	57	49	43	38	33	28	58	51	46	41	36	34	62	56	51	47	42	42				
	236	57	47	41	34	29	21	60	52	46	39	35	30	62	54	49	43	38	35	65	58	54	48	44	44				
	260	*	*	*	*	*	*	62	53	47	40	36	31	64	55	50	43	39	36	67	59	55	49	44	45				
8	165	50	41	37	31	25	--	53	46	42	37	32	25	55	48	46	41	36	31	59	53	52	48	43	42				
	212	53	44	39	32	27	--	57	48	44	38	33	27	59	51	48	42	37	33	62	56	54	49	44	43				
	260	56	46	40	33	28	18	59	50	46	39	34	28	61	53	50	43	38	34	65	58	55	50	45	44				
	330	59	48	42	34	29	20	62	53	48	40	35	30	64	56	51	44	39	36	68	60	57	51	46	46				
	354	*	*	*	*	*	*	63	54	49	41	36	30	65	57	52	44	40	36	69	61	58	51	46	46				
9	189	49	39	34	30	25	19	53	46	39	35	31	28	56	50	42	37	34	33	60	57	48	42	40	41				
	260	52	42	38	33	27	21	57	49	43	37	33	29	59	53	46	40	36	34	64	59	51	45	42	43				
	330	55	44	41	35	29	22	59	51	46	39	34	30	62	55	49	42	38	35	67	61	54	47	43	44				
	425	58	46	44	37	30	23	62	53	49	42	36	31	65	57	52	44	39	37	69	63	57	49	45	45				
	472	*	*	*	*	*	*	63	54	50	43	37	32	66	58	53	45	40	37	71	64	58	50	46	46				
10	236	52	43	39	33	27	21	55	49	45	39	33	28	57	52	48	43	36	33	60	57	54	50	42	40				
	330	55	46	40	34	28	22	59	51	46	40	34	30	61	55	50	44	38	34	64	60	56	50	43	42				
	425	58	48	42	35	29	24	61	54	48	41	35	31	63	57	51	45	39	36	67	62	57	51	44	43				
	519	*	*	*	*	*	*	63	55	49	42	36	32	65	58	52	45	39	37	69	64	58	52	45	44				
	614	*	*	*	*	*	*	65	57	49	42	37	33	67	60	53	46	40	38	71	65	59	52	46	45				
12	330	47	41	35	26	22	19	53	47	40	32	29	27	56	51	42	35	33	32	62	57	46	41	39	41				
	472	51	44	40	31	25	21	57	50	44	36	32	29	60	54	47	40	35	34	66	61	51	45	42	43				
	614	54	46	43	34	27	22	60	53	47	39	34	31	63	57	50	43	37	35	69	63	54	49	44	44				
	755	56	48	46	36	29	23	62	55	50	42	35	32	65	59	52	45	39	37	71	65	57	51	45	45				
	897	*	*	*	*	*	*	64	56	52	44	36	33	67	60	55	47	40	37	73	67	59	53	47	46				
14	472	51	44	38	33	30	25	57	51	43	38	35	33	60	54	46	41	38	37	66	60	52	47	44	45				
	696	55	48	42	36	33	27	61	54	48	41	38	35	64	57	51	44	41	39	70	64	56	50	46	47				
	991	59	50	46	38	35	29	64	57	51	44	40	36	68	60	55	47	43	41	73	66	60	52	48	48				
	1144	*	*	*	*	*	*	66	58	53	45	41	37	69	61	56	48	44	42	75	68	61	53	49	49				
	1369	*	*	*	*	*	*	67	59	55	46	42	38	71	63	58	49	45	42	77	69	63	55	50	50				
16	566	51	44	37	31	26	24	56	51	42	36	31	31	59	55	45	39	34	35	65	61	51	44	39	41				
	838	55	47	42	35	31	29	60	53	48	40	36	35	63	57	51	43	39	39	69	64	56	48	44	46				
	1109	57	49	46	38	35	32	63	55	52	43	40	39	66	59	55	46	42	43	72	66	60	51	47	49				
	1321	*	*	*	*	*	*	65	57	54	45	42	41	68	60	57	48	45	45	73	67	63	53	49	51				
	1652	*	*	*	*	*	*	67	58	57	47	45	43	70	62	60	50	48	47	76	68	66	55	52	54				

Performance Notes:

1. Test data obtained in accordance with AHRI Standard 880-2017 and ASHRAE Standard 130-2016.
2. Sound power levels include duct end corrections per AHRI Standard 880-2017.
3. All data are application ratings. Application ratings are outside the scope of the AHRI 880 Certification Program.
4. Asterisks (*) indicate minimum static pressure of the unit exceeds the minimum operating pressure across the unit.
5. Dashes (-) indicate sound power levels below 36-29-26-22-19-17 for each octave band; values below these sound power levels are considered below significance per AHRI 880.

PERFORMANCE DATA

DDUQ – Standard Mixing Ultra-Quiet Model - Typical Selection Guide

Unit Size	Airflow cfm	Minimum ΔPs		Discharge NC								Radiated NC			
		Across Assembly	Min. ΔPt.	ΔPs Across Unit								ΔPs Across Unit			
		in.w.g.	in.w.g.	(1) 0.5 in.w.g.	(2) 0.5 in.w.g.	(1) 1.0 in.w.g.	(2) 1.0 in.w.g.	(1) 1.5 in.w.g.	(2) 1.5 in.w.g.	(1) 3.0 in.w.g.	(2) 3.0 in.w.g.	0.5 in.w.g.	1.0 in.w.g.	1.5 in.w.g.	3.0 in.w.g.
4	75	0.01	0.06	--	--	--	--	--	--	--	--	--	--	--	--
	100	0.01	0.09	--	--	--	--	--	--	--	--	--	--	--	--
	150	0.01	0.19	--	--	--	--	20	--	23	21	--	--	--	21
	200	0.01	0.33	20	--	23	21	25	23	28	26	23	25	25	27
	225	0.01	0.42	22	--	25	23	27	24	30	28	26	27	28	30
5	150	0.02	0.09	--	--	--	--	--	--	--	--	--	--	--	--
	200	0.04	0.17	--	--	--	--	--	--	22	--	--	--	--	21
	250	0.06	0.27	--	--	20	--	22	--	26	23	--	--	22	25
	300	0.09	0.39	--	--	--	--	21	--	25	22	--	23	25	29
6	200	0.12	0.18	--	--	--	--	--	--	21	--	--	--	--	--
	250	0.19	0.29	--	--	--	--	20	--	25	22	--	--	--	21
	300	0.28	0.41	--	--	--	--	--	--	24	21	--	--	--	23
	350	0.38	0.57	--	--	--	--	22	--	27	24	--	--	22	26
7	400	0.50	0.74	--	--	22	--	24	22	29	26	--	21	24	28
	200	0.06	0.09	--	--	--	--	--	--	21	--	--	--	--	--
	300	0.13	0.20	--	--	--	--	--	--	24	22	--	--	--	24
	400	0.23	0.36	--	--	21	--	24	22	30	27	--	--	23	28
	500	0.36	0.56	--	--	25	23	29	26	34	31	--	23	26	31
8	550	0.44	0.68	22	--	27	25	30	28	36	33	--	24	27	33
	350	0.11	0.16	--	--	--	--	--	--	26	23	--	--	--	23
	450	0.18	0.27	--	--	--	--	23	21	30	27	--	--	21	27
	550	0.28	0.40	--	--	23	20	26	24	33	30	--	20	24	30
	700	0.45	0.66	20	--	26	24	30	27	36	34	--	24	27	33
9	750	0.52	0.76	*	*	25	22	28	26	35	32	*	25	28	34
	400	0.08	0.13	--	--	--	--	--	--	23	--	--	--	--	--
	550	0.15	0.23	--	--	--	--	23	20	28	26	--	--	--	24
	700	0.24	0.38	--	--	24	21	27	24	32	30	--	--	22	28
	900	0.39	0.62	20	--	26	23	29	26	34	32	--	23	27	33
10	1000	0.48	0.76	22	--	28	25	31	28	36	33	--	25	28	34
	500	0.08	0.12	--	--	--	--	20	--	27	24	--	--	--	21
	700	0.16	0.24	--	--	22	--	26	23	32	30	--	--	20	27
	900	0.27	0.40	--	--	24	21	28	25	34	32	--	20	24	31
	1100	0.40	0.60	21	--	28	25	31	29	38	35	--	24	28	34
12	1300	0.55	0.84	*	*	30	28	34	32	41	38	*	27	31	37
	700	0.07	0.11	--	--	--	--	--	--	22	--	--	--	--	22
	1000	0.14	0.22	--	--	--	--	--	--	24	--	--	--	21	28
	1300	0.23	0.37	--	--	--	--	21	--	27	24	--	21	25	32
	1600	0.36	0.56	--	--	21	--	24	21	30	28	--	25	29	36
14	1900	0.50	0.79	--	--	23	20	27	24	33	31	20	28	32	39
	1000	0.09	0.13	--	--	--	--	21	--	28	--	--	--	23	31
	1475	0.18	0.28	--	--	--	--	24	--	31	24	--	23	28	37
	2100	0.36	0.55	--	--	22	--	27	24	34	31	21	28	33	42
	2425	0.47	0.73	--	--	25	22	29	26	36	33	23	30	35	44
16	2900	0.67	1.04	*	*	28	25	32	29	39	36	*	32	38	46
	1200	0.10	0.14	--	--	--	--	--	--	--	--	--	--	23	31
	1775	0.22	0.30	--	--	--	--	--	--	22	--	--	23	28	36
	2350	0.38	0.52	--	--	--	--	22	--	28	25	--	27	32	39
	2800	0.54	0.74	*	*	22	--	25	23	31	29	*	29	34	41
3500	0.83	1.14	*	*	26	23	30	27	36	33	*	32	37	44	

Performance Notes:

- NCs are derived from sound power levels, which are obtained in accordance with AHRI Standard 880-2017 and ASHRAE Standard 130-2016.
- NCs are derived from sound power levels which include duct end corrections per AHRI Standard 880-2017.
- Blank spaces (-) indicate NCs less than 20.
- Asterisks (*) indicate minimum static pressure of the unit exceeds the minimum operating pressure across the unit.
- ΔPs is the difference in static pressure from inlet to discharge of the unit.
- ΔPs for terminal units with electric coil is equal to basic unit. Resistance of the coil elements is negligible.
- ΔPt is the difference in total pressure from inlet to discharge of the unit.

8. NC values are calculated based on procedures outlined in AHRI Standard 885-2008, "A Procedure for Estimating Occupied Space Sound Levels in the Application of Air Terminals and Air Outlets."

Radiated NC is based on a 5/8 in. mineral fiber tile ceiling per AHRI 885-2008, Appendix E typical attenuation values.

Total Deduction	Octave Band Mid Frequency, Hz.					
	125	250	500	1000	2000	4000
All Sizes	18	19	20	26	31	36

(1) Discharge NC is based on environmental effect, end reflection, flex duct and sound power division. No deductions for lined duct are included. These calculations are not covered by AHRI 885-2008 Appendix E.

Total Deduction	Octave Band Mid Frequency, Hz.					
	125	250	500	1000	2000	4000
< 300 cfm	22	22	27	28	30	22
300 – 700 cfm	25	25	30	31	33	25
> 700 cfm	27	27	32	33	35	27

(2) Discharge NC is based on environmental effect, end reflection, flex duct, sound power division and **lined duct** per AHRI 885-2008 Appendix E attenuation values.

Total Deduction	Octave Band Mid Frequency, Hz.					
	125	250	500	1000	2000	4000
< 300 cfm	24	28	39	53	59	40
300 – 700 cfm	27	29	40	51	53	39
> 700 cfm	29	30	41	51	52	39

PERFORMANCE DATA

DDUQ – Standard Mixing Ultra-Quiet Model - Discharge Sound Data

Unit Size	Airflow cfm	Sound Power Levels Lw dB re 10 ⁻¹² Watts																								
		0.5 in.w.g. Octave Band						1.0 in.w.g. Octave Band						1.5 in.w.g. Octave Band						3.0 in.w.g. Octave Band						
		2	3	4	5	6	7	2	3	4	5	6	7	2	3	4	5	6	7	2	3	4	5	6	7	
4	75	50	33	--	--	--	--	52	36	--	--	--	--	54	38	28	--	--	--	18	56	41	31	--	21	24
	100	53	37	--	--	--	--	56	40	29	--	--	18	57	42	31	--	20	22	60	45	35	--	24	27	
	150	59	42	29	--	--	18	61	45	33	--	21	24	62	47	35	--	24	27	65	50	39	--	28	33	
	200	62	46	32	--	20	22	65	49	36	--	24	28	66	51	38	--	26	31	69	54	42	23	31	37	
	225	64	48	34	--	21	24	66	51	37	--	25	29	68	53	40	--	28	33	70	56	43	25	32	38	
5	150	53	37	--	--	--	--	56	40	--	--	21	22	57	42	27	--	23	26	60	45	31	--	27	33	
	200	57	41	26	--	20	19	59	44	30	--	24	26	61	46	32	--	27	30	64	49	35	23	31	37	
	250	60	44	30	--	23	22	62	47	33	--	27	29	64	49	35	23	29	33	67	52	39	26	33	40	
	300	62	47	33	--	25	24	65	50	36	24	29	31	66	52	38	25	31	35	69	55	42	29	35	42	
	350	64	49	35	23	27	26	67	52	39	26	31	33	68	54	41	28	33	37	71	57	44	31	37	44	
6	200	54	41	27	--	20	18	58	44	31	--	24	25	60	46	33	--	26	29	63	50	36	22	30	35	
	250	57	44	31	--	22	21	60	47	34	--	26	28	62	49	36	23	28	31	66	53	39	25	32	38	
	300	59	47	33	22	24	23	63	50	37	24	28	30	65	52	39	26	30	34	68	56	42	28	34	40	
	350	61	49	36	24	26	25	65	52	39	27	30	32	67	54	41	28	32	35	70	58	44	30	36	42	
	400	63	51	38	26	28	27	67	54	41	28	31	33	69	56	43	30	34	37	72	60	46	32	37	44	
7	200	52	40	--	--	--	17	56	44	27	--	21	24	58	47	29	--	23	28	63	51	34	--	27	35	
	300	58	45	29	--	22	22	62	49	33	--	26	29	64	52	36	23	29	33	69	56	40	25	33	40	
	400	62	49	33	24	26	25	66	53	37	26	30	32	69	56	40	27	33	36	73	60	44	30	37	43	
	500	65	51	36	28	29	27	69	56	41	30	33	34	72	58	43	31	36	38	76	63	48	33	40	45	
	550	67	53	38	29	30	28	71	57	42	31	35	35	73	60	45	33	37	39	77	64	49	35	41	46	
8	350	57	41	27	--	25	21	62	47	32	--	28	28	65	50	34	22	30	31	70	55	39	24	33	38	
	450	60	45	31	24	28	24	65	50	35	26	31	31	68	53	38	27	33	35	73	58	43	29	36	41	
	550	63	48	34	28	31	27	67	53	38	30	34	33	70	56	41	31	36	37	75	61	46	33	39	44	
	700	65	52	37	33	34	30	70	57	42	35	37	36	73	60	45	36	39	40	78	65	50	37	42	47	
	750	*	*	*	*	*	*	71	58	43	36	38	37	74	61	46	37	40	41	79	66	51	39	43	47	
9	400	56	40	--	--	24	21	60	44	28	22	28	28	63	47	30	23	30	32	67	51	34	25	33	39	
	550	61	45	30	25	29	25	65	49	34	27	32	32	67	52	36	29	34	36	71	56	39	31	38	43	
	700	64	49	35	29	32	28	68	53	38	31	35	35	71	56	40	33	38	39	75	60	44	35	41	46	
	900	67	52	39	33	35	32	72	57	43	35	39	38	74	59	45	37	41	42	78	64	48	39	44	49	
	1000	69	54	41	35	37	33	73	58	44	37	40	40	75	61	46	38	42	44	80	65	50	40	46	50	
10	500	57	39	27	23	27	27	62	45	32	25	30	32	65	49	35	26	32	36	70	54	39	28	35	41	
	700	62	44	32	28	32	31	67	50	37	30	35	37	70	53	40	32	37	40	75	59	45	34	40	46	
	900	65	48	36	32	35	34	70	54	41	34	39	40	73	57	44	36	40	43	78	63	48	38	43	49	
	1100	68	51	39	35	38	37	73	57	44	38	41	43	76	60	47	39	43	46	81	66	52	41	46	51	
	1300	*	*	*	*	*	*	75	59	47	40	44	45	78	62	49	41	45	48	83	68	54	44	48	54	
12	700	51	41	27	25	30	30	56	46	31	28	33	35	59	48	34	29	35	38	64	53	38	32	38	44	
	1000	56	46	33	30	34	34	61	51	37	33	37	39	64	54	40	34	39	43	69	59	44	37	42	48	
	1300	59	49	38	33	37	37	64	54	42	36	40	42	67	57	44	38	42	46	72	62	48	41	45	51	
	1600	62	52	41	36	40	39	67	57	45	39	43	45	70	60	47	41	45	48	75	65	51	44	48	53	
	1900	64	55	44	39	42	41	69	60	48	42	45	47	72	63	50	43	47	50	77	68	54	46	50	55	
14	1000	53	41	30	28	36	33	59	47	34	32	40	41	62	50	36	34	42	45	67	56	40	38	47	52	
	1475	59	46	37	33	39	36	64	52	41	37	43	44	67	55	43	39	45	48	72	60	47	43	50	56	
	2100	64	51	43	37	42	39	69	56	47	41	46	47	72	60	49	43	48	51	77	65	53	47	52	58	
	2425	66	53	45	39	43	40	71	58	49	43	47	48	74	61	51	45	49	52	79	67	55	49	54	59	
	2900	*	*	*	*	*	*	73	60	52	45	48	49	77	64	54	47	51	53	82	69	58	51	55	61	
16	1200	51	40	28	23	27	26	55	45	32	25	30	32	58	47	34	26	31	36	63	52	37	27	34	42	
	1775	57	46	35	30	32	30	61	50	38	32	35	36	64	53	40	33	37	40	69	58	44	35	40	46	
	2350	61	49	39	36	37	33	66	54	43	37	40	39	68	57	45	38	41	43	73	61	48	40	44	49	
	2800	*	*	*	*	*	*	68	57	46	41	42	41	71	59	47	42	44	45	76	64	51	43	47	51	
	3500	*	*	*	*	*	*	72	60	49	45	45	44	75	62	51	46	47	47	79	67	55	48	50	54	

Performance Notes:

1. Test data obtained in accordance with AHRI Standard 880-2017 and ASHRAE Standard 130-2016.
2. Sound power levels include duct end corrections per AHRI Standard 880-2017.
3. Asterisks (*) indicate minimum static pressure of the unit exceeds the minimum operating pressure across the unit.
4. Dashes (-) indicate sound power levels below 36-29-26-22-19-17 for each octave band; values below these sound power levels are considered below significance per AHRI 880.

PERFORMANCE DATA

DDUQ – Standard Mixing Ultra-Quiet Model - Radiated Sound Data

Unit Size	Airflow cfm	Sound Power Levels Lw dB re 10 ⁻¹² Watts																											
		0.5 in.w.g. Octave Band							1.0 in.w.g. Octave Band							1.5 in.w.g. Octave Band							3.0 in.w.g. Octave Band						
		2	3	4	5	6	7	2	3	4	5	6	7	2	3	4	5	6	7	2	3	4	5	6	7				
4	75	44	30	26	--	--	--	45	33	31	23	19	--	45	34	34	26	23	20	47	37	38	31	28	26				
	100	49	35	30	--	--	--	50	37	34	26	23	19	50	39	37	29	26	22	52	41	41	34	31	28				
	150	56	41	34	26	22	--	57	43	39	31	27	22	57	45	41	34	30	26	59	47	46	38	36	32				
	200	61	45	38	29	25	19	62	48	42	34	30	25	62	49	45	37	33	28	64	52	49	42	39	34				
	225	63	47	39	30	26	20	64	50	43	35	32	26	64	51	46	38	35	29	66	53	51	43	40	35				
5	150	48	34	29	25	21	--	51	38	34	30	25	22	52	40	37	33	28	25	55	44	42	37	33	32				
	200	52	37	32	27	23	18	55	41	37	32	28	25	56	44	40	35	31	28	59	48	45	40	35	35				
	250	55	40	34	29	25	20	58	44	39	34	30	27	60	46	42	36	33	31	62	50	47	41	37	38				
	300	58	42	35	30	27	22	60	46	40	35	31	29	62	49	43	38	34	33	65	53	48	43	39	39				
	350	60	44	37	31	28	24	63	48	42	36	33	30	64	50	45	39	36	34	67	54	50	44	40	41				
6	200	47	34	30	26	22	18	51	39	35	31	27	24	53	42	38	34	30	27	56	47	43	39	35	33				
	250	50	36	32	28	24	20	53	41	37	32	29	26	55	44	40	35	32	29	59	49	45	40	37	35				
	300	52	38	34	29	25	22	55	43	39	34	30	28	57	46	42	36	33	31	61	51	47	41	38	37				
	350	54	40	35	30	27	23	57	45	40	35	32	29	59	48	43	38	34	32	63	53	48	42	39	38				
	400	56	41	37	31	28	24	59	46	42	36	33	30	61	49	45	38	36	34	64	54	50	43	41	40				
7	200	46	34	29	26	--	--	50	39	34	30	24	17	52	42	37	33	27	22	56	48	42	38	33	30				
	300	50	39	33	30	22	--	54	44	38	34	28	21	57	47	41	37	31	26	61	52	46	41	37	34				
	400	54	42	36	32	25	--	58	47	41	37	31	24	60	50	44	40	34	29	64	55	49	44	40	37				
	500	56	45	38	35	27	18	60	50	43	39	33	26	63	53	46	42	36	31	67	58	51	46	42	39				
	550	57	46	39	35	28	19	61	51	44	40	34	27	64	54	47	42	37	32	68	59	52	47	43	40				
8	350	49	37	31	27	23	--	53	43	37	31	27	21	56	46	40	33	29	25	61	51	45	37	33	33				
	450	52	40	35	31	26	17	56	45	40	34	31	24	59	49	43	37	33	29	64	54	48	40	37	36				
	550	54	42	37	34	29	20	59	47	42	37	33	27	61	51	45	40	36	32	66	56	50	43	40	39				
	700	57	44	40	37	33	23	61	50	45	41	37	30	64	53	48	43	39	35	69	59	53	47	43	42				
	750	*	*	*	*	*	*	62	51	46	42	38	31	65	54	49	44	40	36	69	59	54	48	44	43				
9	400	45	36	33	33	28	19	50	41	38	36	32	26	53	44	40	38	35	31	57	49	45	42	39	38				
	550	49	40	36	36	31	22	54	45	41	39	35	29	57	48	43	41	37	33	61	53	48	44	41	40				
	700	53	43	39	38	33	24	57	48	43	41	37	31	60	51	46	43	39	35	65	56	50	46	43	42				
	900	56	46	41	40	35	25	61	51	46	43	39	32	63	54	48	45	41	37	68	59	53	49	46	44				
	1000	57	47	42	41	36	26	62	52	47	44	40	33	65	55	49	46	42	37	69	61	54	49	46	44				
10	500	45	37	34	33	29	19	51	43	38	36	32	25	54	46	41	38	35	29	59	51	46	42	38	35				
	700	50	41	37	36	32	23	55	47	42	40	35	29	58	50	45	42	38	32	63	56	49	45	41	38				
	900	53	44	40	38	34	25	59	50	45	42	38	31	62	53	47	44	40	35	67	59	52	48	44	40				
	1100	56	47	42	40	36	27	61	52	47	44	40	33	64	56	49	46	42	37	69	61	54	50	45	42				
	1300	*	*	*	*	*	*	63	54	48	45	41	35	66	58	51	48	43	38	72	63	56	51	47	44				
12	700	46	38	35	32	29	21	51	43	39	36	33	27	54	46	42	38	35	30	60	51	46	42	39	36				
	1000	50	42	39	35	32	25	56	48	43	39	36	31	59	51	46	41	39	34	65	56	50	45	43	40				
	1300	54	46	42	37	35	28	59	51	46	41	39	34	62	54	49	43	41	37	68	59	53	47	45	43				
	1600	56	48	45	39	37	30	62	53	49	42	41	36	65	56	51	45	43	40	71	62	56	49	47	45				
	1900	58	50	47	40	39	32	64	56	51	44	43	38	67	59	54	46	45	42	73	64	58	50	49	47				
14	1000	50	43	39	31	28	19	56	49	44	36	33	26	60	53	47	39	37	31	67	59	51	45	42	38				
	1475	54	46	43	34	31	24	61	52	48	40	37	31	65	56	51	43	40	35	71	63	56	48	46	42				
	2100	58	49	48	37	35	28	64	56	52	43	40	35	68	59	55	46	43	39	75	66	60	51	49	46				
	2425	59	51	49	39	36	29	66	57	54	44	41	37	70	61	57	47	45	41	77	67	62	52	50	48				
	2900	*	*	*	*	*	*	68	59	56	46	43	39	72	62	59	49	46	43	78	69	64	54	52	50				
16	1200	51	43	37	32	27	17	57	50	42	36	31	24	60	53	45	39	33	27	66	60	50	43	38	33				
	1775	55	46	41	36	31	22	61	53	46	40	35	28	64	57	49	42	38	32	70	63	54	47	42	38				
	2350	58	48	44	38	34	26	64	55	49	43	38	32	67	59	52	45	41	35	73	65	57	49	45	42				
	2800	*	*	*	*	*	*	65	56	51	44	40	34	69	60	53	47	43	38	75	67	59	51	47	44				
	3500	*	*	*	*	*	*	68	58	53	46	43	37	71	62	56	49	45	40	77	68	61	53	49	47				

Performance Notes:

1. Test data obtained in accordance with AHRI Standard 880-2017 and ASHRAE Standard 130-2016.
2. Sound power levels include duct end corrections per AHRI Standard 880-2017.
3. Asterisks (*) indicate minimum static pressure of the unit exceeds the minimum operating pressure across the unit.
4. Dashes (-) indicate sound power levels below 36-29-26-22-19-17 for each octave band; values below these sound power levels are considered below significance per AHRI 880.

PERFORMANCE DATA

DPUQ / DDUQ – Standard Mixing Ultra-Quiet Model - Discharge Sound Power Levels

Hospital Grade Liner (CRAF/PL) - Straight Silencer

Unit Size	Airflow cfm	Sound Power Levels Lw dB re 10 ⁻¹² Watts																							
		0.5 in.w.g.						1.0 in.w.g.						1.5 in.w.g.						3.0 in.w.g.					
		Octave Band						Octave Band						Octave Band						Octave Band					
		2	3	4	5	6	7	2	3	4	5	6	7	2	3	4	5	6	7	2	3	4	5	6	7
4	75	50	36	34	31	24	23	51	38	37	34	24	27	52	39	41	36	24	30	51	41	48	39	28	41
	100	54	41	38	35	24	24	55	43	44	38	24	29	55	44	46	40	25	35	56	46	51	43	34	43
	150	60	48	43	40	24	23	61	50	47	42	26	31	61	51	50	43	32	36	63	53	54	45	41	45
	200	65	53	45	42	22	24	66	55	50	43	28	32	66	56	53	44	33	38	67	58	57	46	42	46
	225	67	56	47	42	22	24	68	58	50	43	29	33	68	59	54	44	35	38	68	61	58	49	43	45
5	150	54	45	39	33	24	25	55	47	43	36	26	35	55	48	46	37	30	41	55	50	53	40	38	52
	200	59	49	42	35	21	29	59	52	49	37	27	39	60	53	51	38	32	46	60	54	56	41	41	55
	250	63	53	46	35	21	29	62	54	51	37	29	39	63	56	53	40	33	45	64	58	58	45	41	55
	300	66	56	48	36	22	29	67	58	52	41	29	39	65	60	55	43	34	44	67	61	60	50	42	54
	350	69	58	49	38	22	28	69	61	54	43	31	39	68	62	57	46	35	44	70	63	61	52	43	53
6	200	57	51	39	33	25	22	59	53	47	37	29	35	61	54	51	39	34	43	62	57	54	42	43	56
	250	61	55	46	36	27	27	62	57	50	40	33	39	64	58	53	43	38	45	66	60	56	48	48	55
	300	64	59	48	38	29	28	66	60	53	43	37	39	68	62	55	47	42	45	69	64	58	51	50	55
	350	67	61	51	40	28	28	69	63	54	46	36	39	71	65	56	48	42	44	72	67	60	53	49	55
	400	69	64	52	41	29	28	71	66	56	46	36	39	73	66	58	49	41	44	74	70	61	54	49	55
7	200	57	45	36	28	24	21	60	50	42	31	26	29	63	53	47	33	28	36	67	57	57	36	32	48
	300	62	52	44	35	27	28	66	57	53	38	32	40	68	60	57	41	36	47	73	64	63	46	41	59
	400	66	57	49	42	35	36	70	61	54	47	40	46	73	64	59	50	44	52	77	69	64	56	49	62
	500	68	60	50	50	36	36	72	65	57	55	42	46	75	67	60	58	46	51	79	73	67	62	51	61
	550	70	63	52	50	37	35	75	67	58	55	44	45	76	70	61	58	46	51	81	74	67	63	52	61
8	350	61	52	38	34	29	25	66	57	46	36	30	33	69	62	48	37	31	36	75	66	56	41	33	44
	450	63	55	43	37	31	30	68	60	49	41	34	37	73	64	52	42	36	41	78	69	60	46	38	47
	550	67	58	46	41	35	34	71	63	52	45	38	40	74	67	56	46	39	45	79	72	64	50	42	52
	700	69	61	50	46	40	39	74	67	57	49	42	45	77	70	60	52	44	48	82	76	68	55	46	56
	750	*	*	*	*	*	*	75	68	57	51	44	46	78	71	62	53	45	50	83	77	69	57	48	56
9	400	57	50	43	38	26	27	62	54	46	41	30	35	66	57	49	44	33	41	70	62	54	49	38	49
	550	62	54	46	44	32	31	67	59	51	48	37	40	69	63	54	51	39	45	74	67	58	55	44	54
	700	66	59	50	47	37	34	70	63	55	51	41	44	73	66	57	54	44	49	78	70	63	58	49	57
	900	68	61	53	51	42	39	74	67	59	54	47	47	77	69	62	58	49	52	82	74	65	61	53	61
	1000	70	64	56	52	44	40	76	68	60	56	48	49	78	71	62	58	51	54	83	75	68	62	56	62
10	500	62	49	41	35	27	36	67	56	47	39	29	41	71	59	51	42	31	46	76	65	56	46	35	52
	700	67	54	46	39	34	40	72	60	52	44	37	47	75	63	56	48	39	51	81	69	62	53	41	56
	900	70	57	50	44	39	44	75	64	56	49	42	50	78	67	60	52	43	54	83	73	65	57	47	60
	1100	72	61	53	47	43	47	78	67	60	53	46	53	80	70	63	55	47	57	86	77	70	59	51	63
	1300	*	*	*	*	*	*	79	69	63	54	50	56	83	72	65	57	51	59	88	78	72	63	54	65
12	700	53	50	38	30	22	35	60	56	42	34	25	41	63	58	45	35	27	45	70	63	51	40	30	54
	1000	58	56	42	34	29	37	65	61	47	38	31	45	68	64	51	40	33	50	75	69	56	45	37	56
	1300	61	58	46	36	33	39	68	64	51	42	36	47	71	67	54	44	38	52	78	72	59	48	42	58
	1600	64	61	49	39	37	41	71	66	53	44	41	49	75	69	56	47	43	53	81	76	61	51	46	60
	1900	66	64	52	42	41	42	73	69	56	46	44	51	77	73	58	49	46	55	83	79	64	53	49	61
14	1000	56	50	42	35	36	41	62	56	47	40	40	49	66	60	50	43	42	52	72	67	54	49	47	60
	1475	61	54	47	38	40	42	67	61	51	44	44	51	70	65	54	47	45	55	76	70	59	52	50	62
	2100	65	59	51	41	44	44	71	64	56	46	48	53	74	68	59	49	49	56	81	74	63	55	53	63
	2425	67	60	52	42	45	45	73	66	57	48	49	53	77	69	60	51	50	57	83	76	64	56	55	64
	2900	*	*	*	*	*	*	74	67	59	50	50	53	79	72	61	52	53	58	85	78	67	58	57	66
16	1200	53	47	39	30	23	30	58	53	45	32	25	37	61	54	48	34	25	42	66	60	51	36	27	49
	1775	58	52	45	35	31	34	62	56	49	38	33	40	66	59	51	40	34	46	71	64	57	43	36	52
	2350	61	54	47	40	38	36	66	59	53	43	40	43	69	63	56	44	40	48	74	67	59	47	42	55
	2800	*	*	*	*	*	*	68	62	54	46	43	45	70	65	56	48	44	50	77	69	62	50	46	56
	3500	*	*	*	*	*	*	71	64	56	49	47	48	74	67	59	51	49	52	79	72	65	54	51	59

Performance Notes:

- Test data obtained in accordance with AHRI Standard 880-2017 and ASHRAE Standard 130-2016.
- Sound power levels include duct end corrections per AHRI Standard 880-2017.
- All data are application ratings. Application ratings are outside the scope of the AHRI 880 Certification Program.
- Asterisks (*) indicate minimum static pressure of the unit exceeds the minimum operating pressure across the unit.
- Dashes (-) indicate sound power levels below 36-29-26-22-19-17 for each octave band; values below these sound power levels are considered below significance per AHRI 880.

PERFORMANCE DATA

DPUQ / DDUQ – Standard Mixing Ultra-Quiet Model - Radiated Sound Power Levels

Hospital Grade Liner (CRAF/PL) - Straight Silencer

Unit Size	Airflow	Sound Power Levels Lw dB re 10 ⁻¹² Watts																											
		0.5 in.w.g.						1.0 in.w.g.						1.5 in.w.g.						3.0 in.w.g.									
		Octave Band						Octave Band						Octave Band						Octave Band									
cfm	2	3	4	5	6	7	2	3	4	5	6	7	2	3	4	5	6	7	2	3	4	5	6	7					
4	75	44	30	26	--	--	--	45	33	31	23	19	--	45	34	34	26	23	20	47	37	38	31	28	26				
	100	49	35	30	--	--	--	50	37	34	26	23	19	50	39	37	29	26	22	52	41	41	34	31	28				
	150	56	41	34	26	22	--	57	43	39	31	27	22	57	45	41	34	30	26	59	47	46	38	36	32				
	200	61	45	38	29	25	19	62	48	42	34	30	25	62	49	45	37	33	28	64	52	49	42	39	34				
	225	63	47	39	30	26	20	64	50	43	35	32	26	64	51	46	38	35	29	66	53	51	43	40	35				
5	150	48	34	29	25	21	--	51	38	34	30	25	22	52	40	37	33	28	25	55	44	42	37	33	32				
	200	52	37	32	27	23	18	55	41	37	32	28	25	56	44	40	35	31	28	59	48	45	40	35	35				
	250	55	40	34	29	25	20	58	44	39	34	30	27	60	46	42	36	33	31	62	50	47	41	37	38				
	300	58	42	35	30	27	22	60	46	40	35	31	29	62	49	43	38	34	33	65	53	48	43	39	39				
	350	60	44	37	31	28	24	63	48	42	36	33	30	64	50	45	39	36	34	67	54	50	44	40	41				
6	200	47	34	30	26	22	18	51	39	35	31	27	24	53	42	38	34	30	27	56	47	43	39	35	33				
	250	50	36	32	28	24	20	53	41	37	32	29	26	55	44	40	35	32	29	59	49	45	40	37	35				
	300	52	38	34	29	25	22	55	43	39	34	30	28	57	46	42	36	33	31	61	51	47	41	38	37				
	350	54	40	35	30	27	23	57	45	40	35	32	29	59	48	43	38	34	32	63	53	48	42	39	38				
	400	56	41	37	31	28	24	59	46	42	36	33	30	61	49	45	38	36	34	64	54	50	43	41	40				
7	200	46	34	29	26	--	--	50	39	34	30	24	17	52	42	37	33	27	22	56	48	42	38	33	30				
	300	50	39	33	30	22	--	54	44	38	34	28	21	57	47	41	37	31	26	61	52	46	41	37	34				
	400	54	42	36	32	25	--	58	47	41	37	31	24	60	50	44	40	34	29	64	55	49	44	40	37				
	500	56	45	38	35	27	18	60	50	43	39	33	26	63	53	46	42	36	31	67	58	51	46	42	39				
	550	57	46	39	35	28	19	61	51	44	40	34	27	64	54	47	42	37	32	68	59	52	47	43	40				
8	350	49	37	31	27	23	--	53	43	37	31	27	21	56	46	40	33	29	25	61	51	45	37	33	33				
	450	52	40	35	31	26	17	56	45	40	34	31	24	59	49	43	37	33	29	64	54	48	40	37	36				
	550	54	42	37	34	29	20	59	47	42	37	33	27	61	51	45	40	36	32	66	56	50	43	40	39				
	700	57	44	40	37	33	23	61	50	45	41	37	30	64	53	48	43	39	35	69	59	53	47	43	42				
	750	*	*	*	*	*	*	62	51	46	42	38	31	65	54	49	44	40	36	69	59	54	48	44	43				
9	400	45	36	33	33	28	19	50	41	38	36	32	26	53	44	40	38	35	31	57	49	45	42	39	38				
	550	49	40	36	36	31	22	54	45	41	39	35	29	57	48	43	41	37	33	61	53	48	44	41	40				
	700	53	43	39	38	33	24	57	48	43	41	37	31	60	51	46	43	39	35	65	56	50	46	43	42				
	900	56	46	41	40	35	25	61	51	46	43	39	32	63	54	48	45	41	37	68	59	53	49	46	44				
	1000	57	47	42	41	36	26	62	52	47	44	40	33	65	55	49	46	42	37	69	61	54	49	46	44				
10	500	45	37	34	33	29	19	51	43	38	36	32	25	54	46	41	38	35	29	59	51	46	42	38	35				
	700	50	41	37	36	32	23	55	47	42	40	35	29	58	50	45	42	38	32	63	56	49	45	41	38				
	900	53	44	40	38	34	25	59	50	45	42	38	31	62	53	47	44	40	35	67	59	52	48	44	40				
	1100	56	47	42	40	36	27	61	52	47	44	40	33	64	56	49	46	42	37	69	61	54	50	45	42				
	1300	*	*	*	*	*	*	63	54	48	45	41	35	66	58	51	48	43	38	72	63	56	51	47	44				
12	700	46	38	35	32	29	21	51	43	39	36	33	27	54	46	42	38	35	30	60	51	46	42	39	36				
	1000	50	42	39	35	32	25	56	48	43	39	36	31	59	51	46	41	39	34	65	56	50	45	43	40				
	1300	54	46	42	37	35	28	59	51	46	41	39	34	62	54	49	43	41	37	68	59	53	47	45	43				
	1600	56	48	45	39	37	30	62	53	49	42	41	36	65	56	51	45	43	40	71	62	56	49	47	45				
	1900	58	50	47	40	39	32	64	56	51	44	43	38	67	59	54	46	45	42	73	64	58	50	49	47				
14	1000	50	43	39	31	28	19	56	49	44	36	33	26	60	53	47	39	37	31	67	59	51	45	42	38				
	1475	54	46	43	34	31	24	61	52	48	40	37	31	65	56	51	43	40	35	71	63	56	48	46	42				
	2100	58	49	48	37	35	28	64	56	52	43	40	35	68	59	55	46	43	39	75	66	60	51	49	46				
	2425	59	51	49	39	36	29	66	57	54	44	41	37	70	61	57	47	45	41	77	67	62	52	50	48				
	2900	*	*	*	*	*	*	68	59	56	46	43	39	72	62	59	49	46	43	78	69	64	54	52	50				
16	1200	51	43	37	32	27	17	57	50	42	36	31	24	60	53	45	39	33	27	66	60	50	43	38	33				
	1775	55	46	41	36	31	22	61	53	46	40	35	28	64	57	49	42	38	32	70	63	54	47	42	38				
	2350	58	48	44	38	34	26	64	55	49	43	38	32	67	59	52	45	41	35	73	65	57	49	45	42				
	2800	*	*	*	*	*	*	65	56	51	44	40	34	69	60	53	47	43	38	75	67	59	51	47	44				
	3500	*	*	*	*	*	*	68	58	53	46	43	37	71	62	56	49	45	40	77	68	61	53	49	47				

Performance Notes:

- Test data obtained in accordance with AHRI Standard 880-2017 and ASHRAE Standard 130-2016.
- Sound power levels include duct end corrections per AHRI Standard 880-2017.
- All data are application ratings. Application ratings are outside the scope of the AHRI 880 Certification Program.
- Asterisks (*) indicate minimum static pressure of the unit exceeds the minimum operating pressure across the unit.
- Dashes (-) indicate sound power levels below 36-29-26-22-19-17 for each octave band; values below these sound power levels are considered below significance per AHRI 880.

PERFORMANCE DATA

DPUQ / DDUQ – Standard Mixing Ultra-Quiet Model - Discharge Sound Power Levels

Hospital Grade Liner (CRWF/PL) - Straight Silencer

Unit Size	Airflow cfm	Sound Power Levels Lw dB re 10 ⁻¹² Watts																							
		0.5 in.w.g.						1.0 in.w.g.						1.5 in.w.g.						3.0 in.w.g.					
		Octave Band						Octave Band						Octave Band						Octave Band					
		2	3	4	5	6	7	2	3	4	5	6	7	2	3	4	5	6	7	2	3	4	5	6	7
4	75	52	36	29	25	22	19	54	39	29	25	22	19	56	41	31	25	22	20	58	44	34	25	24	26
	100	55	40	29	25	22	19	58	43	32	25	22	20	59	45	34	25	23	24	62	48	38	25	27	29
	150	61	45	32	25	22	20	63	48	36	25	24	26	64	50	38	25	27	29	67	53	42	25	31	35
	200	64	49	35	25	23	24	67	52	39	25	27	30	68	54	41	25	29	33	71	57	45	26	34	39
	225	66	51	37	25	24	26	68	54	40	25	28	31	70	56	43	25	31	35	72	59	46	28	35	40
5	150	55	40	29	25	22	19	58	43	29	25	24	24	59	45	30	25	26	28	62	48	34	25	30	35
	200	59	44	29	25	23	21	61	47	33	25	27	28	63	49	35	25	30	32	66	52	38	26	34	39
	250	62	47	33	25	26	24	64	50	36	25	30	31	66	52	38	26	32	35	69	55	42	29	36	42
	300	64	50	36	25	28	26	67	53	39	27	32	33	68	55	41	28	34	37	71	58	45	32	38	44
	350	66	52	38	26	30	28	69	55	42	29	34	35	70	57	44	31	36	39	73	60	47	34	40	46
6	200	56	44	30	25	23	20	60	47	34	25	27	27	62	49	36	25	29	31	65	53	39	25	33	37
	250	59	47	34	25	25	23	62	50	37	25	29	30	64	52	39	26	31	33	68	56	42	28	35	40
	300	61	50	36	25	27	25	65	53	40	27	31	32	67	55	42	29	33	36	70	59	45	31	37	42
	350	63	52	39	27	29	27	67	55	42	30	33	34	69	57	44	31	35	37	72	61	47	33	39	44
	400	65	54	41	29	31	29	69	57	44	31	34	35	71	59	46	33	37	39	74	63	49	35	40	46
7	200	54	43	29	25	22	19	58	47	30	25	24	26	60	50	32	25	26	30	65	54	37	25	30	37
	300	60	48	32	25	25	24	64	52	36	25	29	31	66	55	39	26	32	35	71	59	43	28	36	42
	400	64	52	36	27	29	27	68	56	40	29	33	34	71	59	43	30	36	38	75	63	47	33	40	45
	500	67	54	39	31	32	29	71	59	44	33	36	36	74	61	46	34	39	40	78	66	51	36	43	47
	550	69	56	41	32	33	30	73	60	45	34	38	37	75	63	48	36	40	41	79	67	52	38	44	48
8	350	59	44	30	25	28	23	64	50	35	25	31	30	67	53	37	25	33	33	72	58	42	27	36	40
	450	62	48	34	27	31	26	67	53	38	29	34	33	70	56	41	30	36	37	75	61	46	32	39	43
	550	65	51	37	31	34	29	69	56	41	33	37	35	72	59	44	34	39	39	77	64	49	36	42	46
	700	67	55	40	36	37	32	72	60	45	38	40	38	75	63	48	39	42	42	80	68	53	40	45	49
	750	*	*	*	*	*	*	73	61	46	39	41	39	76	64	49	40	43	43	81	69	54	42	46	49
9	400	58	43	29	25	27	23	62	47	31	25	31	30	65	50	33	26	33	34	69	54	37	28	36	41
	550	63	48	33	28	32	27	67	52	37	30	35	34	69	55	39	32	37	38	73	59	42	34	41	45
	700	66	52	38	32	35	30	70	56	41	34	38	37	73	59	43	36	41	41	77	63	47	38	44	48
	900	69	55	42	36	38	34	74	60	46	38	42	40	76	62	48	40	44	44	80	67	51	42	47	51
	1000	71	57	44	38	40	35	75	61	47	40	43	42	77	64	49	41	45	46	82	68	53	43	49	52
10	500	59	42	30	26	30	29	64	48	35	28	33	34	67	52	38	29	35	38	72	57	42	31	38	43
	700	64	47	35	31	35	33	69	53	40	33	38	39	72	56	43	35	40	42	77	62	48	37	43	48
	900	67	51	39	35	38	36	72	57	44	37	42	42	75	60	47	39	43	45	80	66	51	41	46	51
	1100	70	54	42	38	41	39	75	60	47	41	44	45	78	63	50	42	46	48	83	69	55	44	49	53
	1300	*	*	*	*	*	*	77	62	50	43	47	47	80	65	52	44	48	50	85	71	57	47	51	56
12	700	53	44	30	28	33	32	58	49	34	31	36	37	61	51	37	32	38	40	66	56	41	35	41	46
	1000	58	49	36	33	37	36	63	54	40	36	40	41	66	57	43	37	42	45	71	62	47	40	45	50
	1300	61	52	41	36	40	39	66	57	45	39	43	44	69	60	47	41	45	48	74	65	51	44	48	53
	1600	64	55	44	39	43	41	69	60	48	42	46	47	72	63	50	44	48	50	77	68	54	47	51	55
	1900	66	58	47	42	45	43	71	63	51	45	48	49	74	66	53	46	50	52	79	71	57	49	53	57
14	1000	55	44	33	31	39	35	61	50	37	35	43	43	64	53	39	37	45	47	69	59	43	41	50	54
	1475	61	49	40	36	42	38	66	55	44	40	46	46	69	58	46	42	48	50	74	63	50	46	53	58
	2100	66	54	46	40	45	41	71	59	50	44	49	49	74	63	52	46	51	53	79	68	56	50	55	60
	2425	68	56	48	42	46	42	73	61	52	46	50	50	76	64	54	48	52	54	81	70	58	52	57	61
	2900	*	*	*	*	*	*	75	63	55	48	51	51	79	67	57	50	54	55	84	72	61	54	58	63
16	1200	53	43	31	26	30	28	57	48	35	28	33	34	60	50	37	29	34	38	65	55	40	30	37	44
	1775	59	49	38	33	35	32	63	53	41	35	38	38	66	56	43	36	40	42	71	61	47	38	43	48
	2350	63	52	42	39	40	35	68	57	46	40	43	41	70	60	48	41	44	45	75	64	51	43	47	51
	2800	*	*	*	*	*	*	70	60	49	44	45	43	73	62	50	45	47	47	78	67	54	46	50	53
	3500	*	*	*	*	*	*	74	63	52	48	48	46	77	65	54	49	50	49	81	70	58	51	53	56

Performance Notes:

- Test data obtained in accordance with AHRI Standard 880-2017 and ASHRAE Standard 130-2016.
- Sound power levels include duct end corrections per AHRI Standard 880-2017.
- All data are application ratings. Application ratings are outside the scope of the AHRI 880 Certification Program.
- Asterisks (*) indicate minimum static pressure of the unit exceeds the minimum operating pressure across the unit.
- Dashes (-) indicate sound power levels below 36-29-26-22-19-17 for each octave band; values below these sound power levels are considered below significance per AHRI 880.

PERFORMANCE DATA

DPUQ / DDUQ – Standard Mixing Ultra-Quiet Model - Radiated Sound Power Levels

Hospital Grade Liner (CRWF/PL) - Straight Silencer

Unit Size	Airflow cfm	Sound Power Levels Lw dB re 10 ⁻¹² Watts																							
		0.5 in.w.g.						1.0 in.w.g.						1.5 in.w.g.						3.0 in.w.g.					
		Octave Band						Octave Band						Octave Band						Octave Band					
		2	3	4	5	6	7	2	3	4	5	6	7	2	3	4	5	6	7	2	3	4	5	6	7
4	75	44	30	26	--	--	--	45	33	31	23	19	--	45	34	34	26	23	20	47	37	38	31	28	26
	100	49	35	30	--	--	--	50	37	34	26	23	19	50	39	37	29	26	22	52	41	41	34	31	28
	150	56	41	34	26	22	--	57	43	39	31	27	22	57	45	41	34	30	26	59	47	46	38	36	32
	200	61	45	38	29	25	19	62	48	42	34	30	25	62	49	45	37	33	28	64	52	49	42	39	34
	225	63	47	39	30	26	20	64	50	43	35	32	26	64	51	46	38	35	29	66	53	51	43	40	35
5	150	48	34	29	25	21	--	51	38	34	30	25	22	52	40	37	33	28	25	55	44	42	37	33	32
	200	52	37	32	27	23	18	55	41	37	32	28	25	56	44	40	35	31	28	59	48	45	40	35	35
	250	55	40	34	29	25	20	58	44	39	34	30	27	60	46	42	36	33	31	62	50	47	41	37	38
	300	58	42	35	30	27	22	60	46	40	35	31	29	62	49	43	38	34	33	65	53	48	43	39	39
	350	60	44	37	31	28	24	63	48	42	36	33	30	64	50	45	39	36	34	67	54	50	44	40	41
6	200	47	34	30	26	22	18	51	39	35	31	27	24	53	42	38	34	30	27	56	47	43	39	35	33
	250	50	36	32	28	24	20	53	41	37	32	29	26	55	44	40	35	32	29	59	49	45	40	37	35
	300	52	38	34	29	25	22	55	43	39	34	30	28	57	46	42	36	33	31	61	51	47	41	38	37
	350	54	40	35	30	27	23	57	45	40	35	32	29	59	48	43	38	34	32	63	53	48	42	39	38
	400	56	41	37	31	28	24	59	46	42	36	33	30	61	49	45	38	36	34	64	54	50	43	41	40
7	200	46	34	29	26	--	--	50	39	34	30	24	17	52	42	37	33	27	22	56	48	42	38	33	30
	300	50	39	33	30	22	--	54	44	38	34	28	21	57	47	41	37	31	26	61	52	46	41	37	34
	400	54	42	36	32	25	--	58	47	41	37	31	24	60	50	44	40	34	29	64	55	49	44	40	37
	500	56	45	38	35	27	18	60	50	43	39	33	26	63	53	46	42	36	31	67	58	51	46	42	39
	550	57	46	39	35	28	19	61	51	44	40	34	27	64	54	47	42	37	32	68	59	52	47	43	40
8	350	49	37	31	27	23	--	53	43	37	31	27	21	56	46	40	33	29	25	61	51	45	37	33	33
	450	52	40	35	31	26	17	56	45	40	34	31	24	59	49	43	37	33	29	64	54	48	40	37	36
	550	54	42	37	34	29	20	59	47	42	37	33	27	61	51	45	40	36	32	66	56	50	43	40	39
	700	57	44	40	37	33	23	61	50	45	41	37	30	64	53	48	43	39	35	69	59	53	47	43	42
	750	*	*	*	*	*	*	62	51	46	42	38	31	65	54	49	44	40	36	69	59	54	48	44	43
9	400	45	36	33	33	28	19	50	41	38	36	32	26	53	44	40	38	35	31	57	49	45	42	39	38
	550	49	40	36	36	31	22	54	45	41	39	35	29	57	48	43	41	37	33	61	53	48	44	41	40
	700	53	43	39	38	33	24	57	48	43	41	37	31	60	51	46	43	39	35	65	56	50	46	43	42
	900	56	46	41	40	35	25	61	51	46	43	39	32	63	54	48	45	41	37	68	59	53	49	46	44
	1000	57	47	42	41	36	26	62	52	47	44	40	33	65	55	49	46	42	37	69	61	54	49	46	44
10	500	45	37	34	33	29	19	51	43	38	36	32	25	54	46	41	38	35	29	59	51	46	42	38	35
	700	50	41	37	36	32	23	55	47	42	40	35	29	58	50	45	42	38	32	63	56	49	45	41	38
	900	53	44	40	38	34	25	59	50	45	42	38	31	62	53	47	44	40	35	67	59	52	48	44	40
	1100	56	47	42	40	36	27	61	52	47	44	40	33	64	56	49	46	42	37	69	61	54	50	45	42
	1300	*	*	*	*	*	*	63	54	48	45	41	35	66	58	51	48	43	38	72	63	56	51	47	44
12	700	46	38	35	32	29	21	51	43	39	36	33	27	54	46	42	38	35	30	60	51	46	42	39	36
	1000	50	42	39	35	32	25	56	48	43	39	36	31	59	51	46	41	39	34	65	56	50	45	43	40
	1300	54	46	42	37	35	28	59	51	46	41	39	34	62	54	49	43	41	37	68	59	53	47	45	43
	1600	56	48	45	39	37	30	62	53	49	42	41	36	65	56	51	45	43	40	71	62	56	49	47	45
	1900	58	50	47	40	39	32	64	56	51	44	43	38	67	59	54	46	45	42	73	64	58	50	49	47
14	1000	50	43	39	31	28	19	56	49	44	36	33	26	60	53	47	39	37	31	67	59	51	45	42	38
	1475	54	46	43	34	31	24	61	52	48	40	37	31	65	56	51	43	40	35	71	63	56	48	46	42
	2100	58	49	48	37	35	28	64	56	52	43	40	35	68	59	55	46	43	39	75	66	60	51	49	46
	2425	59	51	49	39	36	29	66	57	54	44	41	37	70	61	57	47	45	41	77	67	62	52	50	48
	2900	*	*	*	*	*	*	68	59	56	46	43	39	72	62	59	49	46	43	78	69	64	54	52	50
16	1200	51	43	37	32	27	17	57	50	42	36	31	24	60	53	45	39	33	27	66	60	50	43	38	33
	1775	55	46	41	36	31	22	61	53	46	40	35	28	64	57	49	42	38	32	70	63	54	47	42	38
	2350	58	48	44	38	34	26	64	55	49	43	38	32	67	59	52	45	41	35	73	65	57	49	45	42
	2800	*	*	*	*	*	*	65	56	51	44	40	34	69	60	53	47	43	38	75	67	59	51	47	44
	3500	*	*	*	*	*	*	68	58	53	46	43	37	71	62	56	49	45	40	77	68	61	53	49	47

Performance Notes:

- Test data obtained in accordance with AHRI Standard 880-2017 and ASHRAE Standard 130-2016.
- Sound power levels include duct end corrections per AHRI Standard 880-2017.
- All data are application ratings. Application ratings are outside the scope of the AHRI 880 Certification Program.
- Asterisks (*) indicate minimum static pressure of the unit exceeds the minimum operating pressure across the unit.
- Dashes (-) indicate sound power levels below 36-29-26-22-19-17 for each octave band; values below these sound power levels are considered below significance per AHRI 880.

PERFORMANCE DATA

DPM / DDM – High-Mixing Model - Typical Selection Guide

Unit Size	Airflow cfm	Minimum ΔP_s in.w.g.	Min. ΔP_t in.w.g.	Discharge NC ΔP_s Across Unit				Radiated NC ΔP_s Across Unit			
				0.5 in.w.g.	1.0 in.w.g.	1.5 in.w.g.	3.0 in.w.g.	0.5 in.w.g.	1.0 in.w.g.	1.5 in.w.g.	3.0 in.w.g.
4	75	0.06	0.10	--	--	--	--	--	--	--	--
	100	0.10	0.18	--	--	--	--	--	--	--	--
	150	0.21	0.39	--	--	--	--	--	--	--	24
	200	0.35	0.67	--	20	21	24	--	21	24	28
	225	0.43	0.84	--	22	24	26	--	23	26	30
5	150	0.08	0.15	--	--	--	--	--	--	--	--
	200	0.13	0.26	--	--	--	21	--	--	--	20
	250	0.19	0.39	--	20	22	25	--	--	--	23
	300	0.25	0.55	--	--	21	25	--	--	--	26
	350	0.33	0.73	--	22	24	27	--	--	22	28
6	200	0.12	0.18	--	--	--	21	--	--	--	21
	250	0.18	0.27	--	--	20	24	--	--	--	23
	300	0.25	0.38	--	--	--	23	--	--	--	26
	350	0.33	0.51	--	--	21	25	--	--	22	28
	400	0.41	0.65	--	21	23	27	--	--	23	30
7	200	0.06	0.09	--	--	--	--	--	--	--	--
	300	0.13	0.20	--	--	--	21	--	--	--	23
	400	0.24	0.36	--	--	21	26	--	--	22	28
	500	0.37	0.57	--	23	25	30	--	21	25	32
	550	0.45	0.68	--	24	27	32	--	23	27	33
8	350	0.12	0.17	--	--	20	26	--	--	--	24
	450	0.20	0.28	--	21	24	29	--	--	21	28
	550	0.30	0.42	--	24	27	32	--	--	24	31
	700	0.48	0.69	23	28	31	36	--	24	28	35
	750	0.55	0.79	*	26	29	35	*	25	29	36
9	400	0.08	0.12	--	--	--	23	--	--	--	25
	550	0.15	0.23	--	--	22	28	--	--	--	28
	700	0.24	0.38	--	23	26	31	--	--	23	30
	900	0.40	0.62	--	24	27	33	--	21	25	32
	1000	0.49	0.77	20	25	29	34	--	22	26	34
10	500	0.11	0.15	--	--	--	25	--	--	--	26
	700	0.22	0.31	--	20	24	30	--	--	21	29
	900	0.37	0.51	--	22	25	31	--	--	23	31
	1100	0.56	0.76	*	25	28	35	*	21	25	33
	1300	0.78	1.07	*	27	31	37	*	23	27	35
12	700	0.08	0.12	--	--	21	28	--	--	--	30
	1000	0.17	0.24	--	--	23	31	--	--	23	33
	1300	0.28	0.41	--	23	27	35	--	20	26	36
	1600	0.42	0.62	--	26	30	38	--	22	28	38
	1900	0.59	0.87	*	28	33	40	*	24	30	39
14	1000	0.13	0.18	--	--	--	27	--	--	25	35
	1475	0.29	0.38	--	21	26	33	--	25	31	41
	2100	0.58	0.77	*	27	31	39	*	30	36	46
	2425	0.77	1.03	*	29	34	41	*	32	38	48
	2900	1.10	1.47	*	*	37	44	*	*	40	51
16	1200	0.08	0.12	--	--	--	23	--	--	24	32
	1775	0.18	0.26	--	--	22	29	--	24	29	37
	2350	0.31	0.44	--	22	26	33	--	28	33	41
	2800	0.43	0.63	--	25	29	36	22	30	35	43
	3500	0.66	0.97	*	28	32	39	*	33	38	46

Performance Notes:

- NCs are derived from sound power levels, which are obtained in accordance with AHRI Standard 880-2017 and ASHRAE Standard 130-2016.
- NCs are derived from sound power levels which include duct end corrections per AHRI Standard 880-2016.
- Blank spaces (--) indicate NCs less than 20.
- Asterisks (*) indicate minimum static pressure of the unit exceeds the minimum operating pressure across the unit.
- ΔP_s is the difference in static pressure from inlet to discharge of the unit.
- ΔP_t for terminal units with electric coil is equal to basic unit. Resistance of the coil elements is negligible.
- ΔP_t is the difference in total pressure from inlet to discharge of the unit.
- NC values are calculated based on typical attenuation values outlined in Appendix E, AHRI Standard 885-2008, "A Procedure for Estimating Occupied Space Sound Levels in the Application of Air Terminals and Air Outlets."

Typical Attenuation Values:

Radiated Sound

Total Deduction	Octave Band Mid Frequency, Hz					
	120	250	500	1000	2000	4000
All Sizes	18	19	20	26	31	36

Discharge Sound

Total Deduction	Octave Band Mid Frequency, Hz					
	120	250	500	1000	2000	4000
< 300 cfm	24	28	39	53	59	40
300-700 cfm	27	29	40	51	53	39
> 700 cfm	29	30	41	51	52	39

DUAL DUCT

Terminal Units

PERFORMANCE DATA

DPM / DDM – High-Mixing Model - Discharge Sound Data

Unit Size	Airflow cfm	Sound Power Levels Lw dB re 10 ⁻¹² Watts																											
		0.5 in.w.g. Octave Band							1.0 in.w.g. Octave Band							1.5 in.w.g. Octave Band							3.0 in.w.g. Octave Band						
		2	3	4	5	6	7	2	3	4	5	6	7	2	3	4	5	6	7	2	3	4	5	6	7				
4	75	48	30	--	--	--	--	50	32	--	--	--	--	51	33	--	--	--	--	53	35	27	--	--	--				
	100	52	35	27	26	--	--	54	37	29	27	20	--	55	38	30	27	21	18	57	39	32	28	23	21				
	150	58	42	34	35	30	23	60	44	36	36	32	26	61	45	37	37	32	28	63	46	39	38	34	31				
	200	62	47	39	42	38	30	64	49	41	43	40	33	65	50	42	43	40	35	67	51	44	44	42	38				
	225	64	49	41	44	41	33	66	51	43	45	43	36	67	52	44	46	44	38	69	53	46	47	45	41				
5	150	55	37	28	26	19	--	57	40	30	27	20	--	59	41	31	28	21	--	61	44	33	28	22	19				
	200	59	41	33	33	27	20	61	44	35	33	28	22	63	46	36	34	29	24	65	48	38	35	30	26				
	250	62	45	36	37	33	26	64	47	38	38	35	28	66	49	39	39	35	29	68	52	41	40	36	31				
	300	64	47	39	41	38	30	67	50	41	42	40	32	68	52	43	43	40	34	71	55	45	44	42	36				
	350	66	50	42	45	43	34	69	53	44	46	44	36	70	54	45	46	45	37	73	57	47	47	46	40				
6	200	57	41	30	28	22	26	60	45	32	29	24	29	62	47	34	30	25	31	65	51	36	31	27	34				
	250	59	45	34	33	28	29	63	48	36	34	30	32	64	50	38	35	31	34	67	54	40	36	33	37				
	300	62	47	37	37	33	32	65	51	39	38	35	35	67	53	41	39	36	36	70	56	43	40	38	39				
	350	63	49	39	41	37	34	67	53	42	42	39	37	68	55	43	43	40	38	71	58	46	44	42	41				
	400	65	51	42	44	40	36	68	55	44	45	42	39	70	57	46	46	43	40	73	60	48	47	45	43				
7	200	53	41	32	25	--	--	56	44	33	25	--	--	59	46	33	25	--	--	62	48	35	25	--	--				
	300	58	47	39	36	30	21	62	50	40	35	29	22	64	51	41	35	29	22	68	54	42	35	29	22				
	400	62	51	44	43	38	32	66	54	46	43	38	33	68	56	46	43	38	33	72	58	47	43	38	33				
	500	66	55	49	49	45	41	69	57	50	49	45	41	71	59	50	49	45	41	75	61	52	49	45	42				
	550	67	56	50	51	48	45	71	59	51	51	48	45	73	60	52	51	48	45	76	63	53	51	48	45				
8	350	61	48	39	37	32	26	65	53	42	38	34	28	67	55	44	39	34	29	71	60	47	41	36	31				
	450	64	51	43	42	38	32	68	55	46	43	40	34	70	58	48	44	41	35	74	63	51	46	42	38				
	550	66	53	45	46	43	37	70	58	49	47	45	39	73	61	50	48	45	40	77	65	54	50	47	43				
	700	69	56	49	50	49	43	73	61	52	52	50	45	76	63	54	53	51	46	80	68	57	54	53	48				
	750	*	*	*	*	*	*	74	62	53	53	52	47	76	64	55	54	53	48	80	69	58	56	54	50				
9	400	59	45	38	33	31	24	63	49	41	34	31	25	65	51	43	34	31	26	70	55	46	35	32	27				
	550	62	48	42	39	38	31	67	52	45	40	39	33	69	55	47	41	39	34	73	59	51	42	39	35				
	700	65	51	46	44	44	37	69	55	49	45	44	39	72	57	51	46	45	40	76	61	54	47	45	41				
	900	68	54	50	49	50	44	72	58	53	50	50	45	75	60	55	51	51	46	79	64	58	52	51	47				
	1000	69	55	51	51	52	46	73	59	54	52	53	48	76	61	56	53	53	48	80	65	59	54	54	50				
10	500	58	44	38	31	30	22	63	49	42	32	30	24	66	52	44	33	31	25	71	57	47	34	32	27				
	700	62	48	44	38	38	33	67	53	47	40	39	34	70	56	49	40	39	35	75	61	53	42	40	37				
	900	66	51	48	44	44	41	70	56	51	45	45	42	73	59	53	46	45	43	78	64	57	47	46	45				
	1100	*	*	*	*	*	*	73	58	54	50	50	48	76	61	56	51	50	49	81	66	60	52	51	51				
	1300	*	*	*	*	*	*	75	60	57	54	54	53	78	63	59	54	54	54	83	68	62	56	55	56				
12	700	58	44	35	32	26	23	64	50	39	32	27	24	68	53	41	33	28	24	73	59	44	34	30	26				
	1000	63	48	40	39	35	30	68	53	44	40	36	31	72	57	46	41	37	32	78	62	49	42	39	33				
	1300	66	51	44	45	41	36	71	56	48	46	43	37	75	59	50	46	44	37	81	65	53	47	45	38				
	1600	68	53	47	49	47	40	74	58	51	50	48	41	77	62	53	51	49	42	83	67	56	52	50	43				
	1900	*	*	*	*	*	*	76	60	53	54	52	45	79	63	55	55	53	45	85	69	58	55	55	46				
14	1000	59	46	41	36	32	26	65	52	45	38	34	28	69	55	46	39	35	30	74	61	50	40	37	32				
	1475	64	51	49	45	41	36	70	56	52	47	43	38	74	60	54	47	44	39	79	65	57	49	47	42				
	2100	*	*	*	*	*	*	75	60	59	55	51	47	78	64	60	55	53	49	84	69	64	57	55	51				
	2425	*	*	*	*	*	*	76	62	61	58	55	51	80	65	63	59	56	52	86	71	67	60	58	54				
	2900	*	*	*	*	*	*	*	*	*	*	*	*	82	67	67	63	60	57	88	73	70	64	62	59				
16	1200	57	47	40	36	30	23	63	52	42	37	32	27	66	55	43	38	33	29	72	60	45	40	35	33				
	1775	62	51	48	43	38	32	68	56	50	45	41	36	71	59	51	46	42	38	76	64	53	47	44	42				
	2350	65	54	53	48	44	39	71	60	56	50	47	42	74	63	57	51	48	44	80	68	59	53	50	48				
	2800	67	56	57	52	48	43	73	61	59	53	51	46	76	64	60	54	52	48	82	70	63	56	54	52				
	3500	*	*	*	*	*	*	76	64	64	58	56	52	79	67	65	58	57	54	84	72	67	60	59	57				

Performance Notes:

1. Test data obtained in accordance with AHRI Standard 880-2017 and ASHRAE Standard 130-2016.
2. Sound power levels include duct end corrections per AHRI Standard 880-2017.
3. Asterisks (*) indicate minimum static pressure of the unit exceeds the minimum operating pressure across the unit.
4. Dashes (-) indicate sound power levels below 36-29-26-22-19-17 for each octave band; values below these sound power levels are considered below significance per AHRI 880.

DUAL DUCT

Terminal Units

PERFORMANCE DATA

DPM / DDM – High-Mixing Model - Radiated Sound Data

Sound Power Levels Lw dB re 10⁻¹² Watts

Unit Size	Airflow cfm	0.5 in.w.g. Octave Band						1.0 in.w.g. Octave Band						1.5 in.w.g. Octave Band						3.0 in.w.g. Octave Band					
		2	3	4	5	6	7	2	3	4	5	6	7	2	3	4	5	6	7	2	3	4	5	6	7
		75	42	36	--	--	--	--	45	39	31	22	20	--	47	42	34	25	21	--	50	45	39	29	23
100	46	40	28	22	22	20	49	43	34	26	24	21	51	46	37	29	25	22	54	49	42	33	28	23	
150	51	45	33	28	28	29	55	49	38	32	30	31	56	51	41	34	31	31	60	55	46	38	34	33	
200	55	49	36	32	32	36	59	53	41	36	35	37	60	55	44	38	36	38	64	59	49	42	38	39	
225	57	51	37	33	34	39	60	54	42	37	36	40	62	57	45	40	38	41	65	60	50	44	40	42	
4	150	44	36	28	--	--	--	48	41	34	26	21	--	50	44	37	28	23	--	54	49	43	33	26	19
	200	47	40	31	25	23	18	51	44	37	30	26	20	53	47	40	32	27	22	57	52	46	37	30	24
	250	50	42	33	28	27	22	53	47	39	32	29	25	56	50	42	35	31	26	59	55	48	39	34	29
	300	52	44	34	30	29	26	55	49	40	35	32	29	58	52	44	37	34	30	61	57	50	42	36	33
	350	53	46	36	32	32	29	57	51	42	37	34	32	59	53	45	39	36	33	63	58	51	44	39	36
5	200	46	39	30	23	23	20	50	44	36	28	25	22	53	47	40	31	26	24	56	52	46	37	29	26
	250	48	41	32	26	25	22	52	46	38	31	27	24	55	49	42	34	29	25	58	55	48	39	31	28
	300	50	43	33	28	27	23	54	48	40	33	29	26	56	51	43	36	31	27	60	57	49	41	33	29
	350	51	45	35	29	29	25	55	50	41	35	31	27	58	53	45	38	33	28	62	58	51	43	35	30
	400	53	46	36	31	30	26	57	52	42	36	33	28	59	55	46	39	34	29	63	60	52	44	36	31
6	200	43	30	28	25	25	22	48	36	33	28	28	25	50	39	35	30	29	27	55	45	39	32	32	31
	300	48	36	32	28	27	23	53	41	36	31	30	27	56	44	39	33	32	29	61	50	43	35	35	32
	400	51	39	35	30	29	24	56	45	39	33	32	28	59	48	41	35	33	30	64	53	45	37	36	33
	500	54	42	37	32	30	25	59	48	41	35	33	29	62	51	43	36	35	31	67	56	47	39	38	34
	550	56	43	37	33	31	26	61	49	42	35	34	29	63	52	44	37	35	31	68	57	48	40	38	34
7	350	47	34	33	28	27	20	52	40	38	31	29	22	56	44	40	32	30	22	61	50	44	35	31	24
	450	50	37	35	30	28	24	56	43	39	32	30	25	59	47	42	34	31	26	64	53	46	37	33	27
	550	53	39	37	31	29	27	58	45	41	34	31	28	61	49	44	35	32	29	67	55	48	38	34	30
	700	56	42	39	33	31	31	61	48	43	35	32	32	64	52	45	37	33	33	70	58	50	39	35	34
	750	*	*	*	*	*	*	62	49	43	36	33	33	65	52	46	37	34	34	71	58	50	40	35	35
8	400	47	40	35	29	25	21	52	46	39	33	28	26	55	50	41	35	30	29	61	56	45	39	33	34
	550	49	41	37	31	26	22	55	48	41	35	30	27	58	52	43	37	31	30	64	58	47	41	35	35
	700	51	43	39	32	27	22	57	49	43	36	31	27	60	53	45	38	32	30	66	60	49	42	36	35
	900	54	44	40	34	29	23	59	51	44	37	32	28	62	54	47	39	34	31	68	61	51	43	37	36
	1000	54	45	41	34	29	23	60	51	45	38	32	28	63	55	47	40	34	31	69	62	51	44	37	36
9	500	46	39	30	24	19	17	52	46	36	29	24	22	55	50	39	32	27	25	61	57	45	38	31	30
	700	49	41	34	27	21	18	55	48	39	32	26	23	58	52	42	35	29	26	64	59	48	40	33	31
	900	51	43	36	28	23	19	57	50	42	34	27	24	61	54	45	37	30	27	66	61	50	42	34	32
	1100	*	*	*	*	*	*	59	51	44	35	28	24	62	55	47	38	31	27	68	62	52	43	36	32
	1300	*	*	*	*	*	*	60	52	45	36	29	25	64	56	49	39	32	28	70	64	54	44	36	33
10	700	46	38	33	25	22	22	54	45	38	30	27	29	58	49	41	33	29	33	66	56	45	38	34	40
	1000	49	41	36	28	24	24	56	48	41	33	29	31	61	52	43	35	32	35	68	59	48	40	37	42
	1300	51	43	38	30	26	25	58	50	43	35	30	32	63	54	46	38	33	36	70	62	50	42	38	43
	1600	52	44	40	31	27	26	60	52	44	36	32	33	64	56	47	39	35	37	72	63	52	44	39	44
	1900	*	*	*	*	*	*	61	53	46	38	33	34	66	57	49	40	36	38	73	65	53	45	40	45
12	1000	49	38	33	25	20	--	57	46	39	30	25	21	62	50	42	33	27	23	70	58	48	39	32	27
	1475	54	41	38	29	24	20	62	48	43	34	29	24	66	53	47	37	32	27	74	60	52	43	37	31
	2100	*	*	*	*	*	*	66	51	48	38	33	27	70	55	51	41	36	30	78	63	56	46	41	34
	2425	*	*	*	*	*	*	67	52	49	39	34	28	72	56	52	42	37	31	80	64	58	48	42	35
	2900	*	*	*	*	*	*	*	*	*	*	*	*	74	57	55	44	39	33	82	65	60	50	44	37
14	1200	51	42	36	29	23	--	57	48	41	34	27	21	61	52	44	36	29	23	68	58	49	41	33	28
	1775	55	46	40	33	28	20	61	52	45	38	32	25	65	55	48	40	34	28	72	61	53	45	38	33
	2350	58	48	43	36	31	24	64	54	48	41	35	29	68	58	51	43	37	32	74	64	56	47	41	37
	2800	59	50	45	38	33	26	66	56	50	42	37	31	70	59	53	45	39	34	76	65	58	49	43	39
	3500	*	*	*	*	*	*	68	58	53	45	40	34	72	61	56	47	42	36	78	67	61	52	46	41

Performance Notes:

1. Test data obtained in accordance with AHRI Standard 880-2017 and ASHRAE Standard 130-2017.
2. Sound power levels include duct end corrections per AHRI Standard 880-2017.
3. Asterisks (*) indicate minimum static pressure of the unit exceeds the minimum operating pressure across the unit.
4. Dashes (-) indicate sound power levels below 36-29-26-22-19-17 for each octave band; values below these sound power levels are considered below significance per AHRI 880.

PRICE | **TERMINAL UNITS**

Product Improvement is a continuing endeavour at Price. Therefore, specifications are subject to change without notice. Consult your Price Sales Representative for current specifications or more detailed information. Not all products may be available in all geographic areas. All goods described in this document are warranted as described in the Limited Warranty shown at priceindustries.com. The complete Price product catalog can be viewed online at priceindustries.com.